

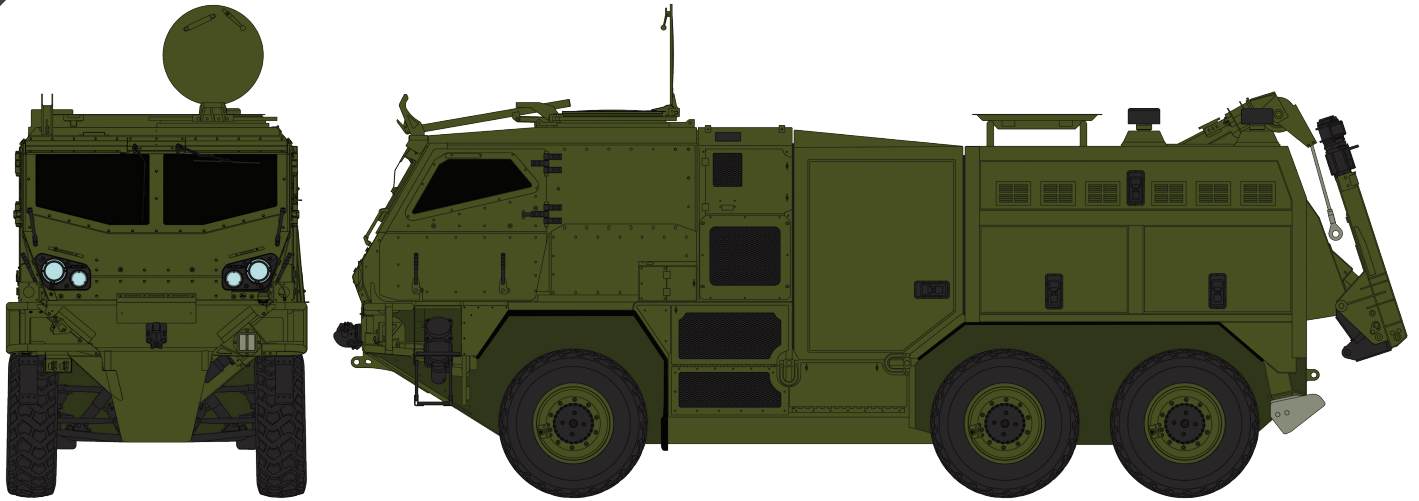

HMT LWR

HMT Light Weight Recovery
SPECIFICATION SHEET



Developed for the UK MoD's Light Weight (Air Portable) Recovery Capability (LW(AP)RC), this all-new 6x6 Supacat variant is based on the acclaimed HMT 600 vehicle, most commonly known as Coyote. The HMT LWR leverages the supreme off-road mobility offered by HMT's unique and battle-proven automotive design including the variable height air suspension system, dependable engine and multi-mode driveline. A fully integrated blast and ballistic protection system completes the picture, providing the very best levels of protection that can be offered by a vehicle of this type, size and weight. As with all HMT platforms, the modular hamper design can be reconfigured to suit a customer's specific requirements with regards to capability, layout and stowage.

With mobility levels matching those delivered by the sister Jackal and Coyote fighting variants, the HMT Light Weight Recovery is designed to recover casualty vehicles from the most challenging urban and rural environments, whilst providing optimum levels of crew protection. The HMT LWR breaks new ground in terms of high mobility, recovery capability and as such, is unmatched in tactically recovering casualty vehicles, within the specified size and weight envelope.

A	Length	7378 mm
B	Width	2100 mm
C	Height	Min 2554 mm Max 2754 mm
D	Track	1700 mm
E	Wheelbase to Axle 2	3000 mm
F	Wheelbase to Axle 3	4250 mm
G	Front Overhang	1643 mm
H	Rear Overhang	1485 mm
I	Ground Clearance	Min 180 mm Max 485 mm
J	Approach Angle	40°
K	Departure Angle	38°
L	Ramp Over Angle	150°

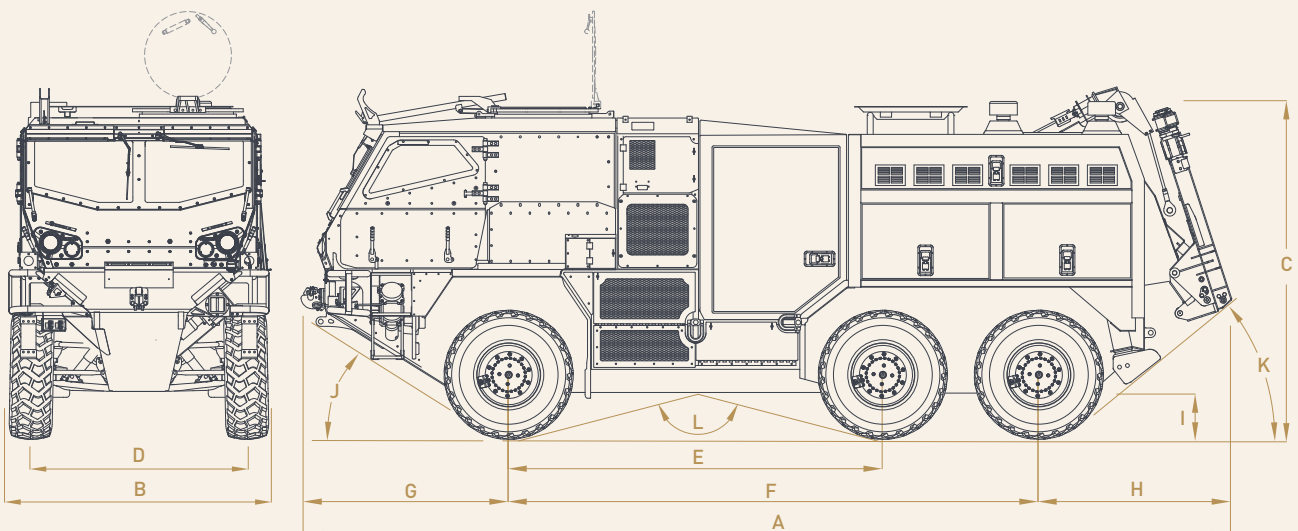

HMT LWR Vehicle Specification

Weight	10500 kg
Kerb weight	6600 kg
Turning circle (kerb to kerb)	17.5 m
Speed	120 km/h
Fuel capacity	200 Litres
Maximum road range solo	700 km
Fording	750mm (unprepared) 1500mm (prepared) + 500mm Splash
Gradient	60 %
Engine	Cummins 5.9L (6.7L compatible), 6 cylinder Diesel 185hp, 700Nm torque
Transmission	5 speed automatic
Drive	4WD / 6WD , High / Low range
Brakes	Air over hydraulic system, ABS
Differentials	Limited slip
Steering	Power assisted
Tyres	335/80 R20
Electrical system	24 V DC
Suspension	Independent with air adjustable ride height
Main Winch	10 T
Max winching height	4 m
Max recovered vehicle axle mass	Conventional mode: 3.8 T Supalift mode (Patent Pending): 6 T
Self Recovery Winch	6.2 T

Options

Runflat tyres, locking differentials, remote weapons station, smoke grenade launchers, RHD or LHD.

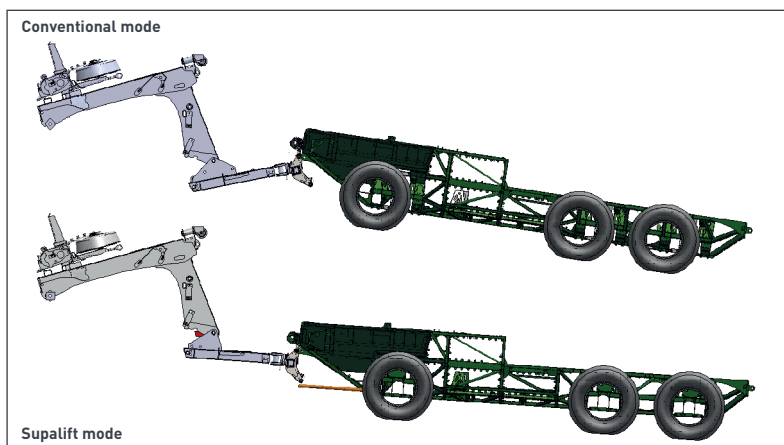

HMT LWR utilises innovative `Supalift` technology, developed by Supacat and pending patent, which has made the concept of a light weight recovery vehicle operationally viable for the first time. The `Supalift` design centres on a pivoting joint reconfiguring and reducing the recovery system's lever arm, which distributes the weight of the casualty vehicle more evenly over the recovery vehicle. The operator can switch the recovery system from conventional mode, with a maximum recovered vehicle axle mass of approximately 3.8 tonnes, to the Supalift mode, capable of lifting approximately 6 tonnes.



HMT Light Weight Recovery



HMT Light Weight Recovery with hamper removed



Like for like recovery



Concept demonstrator