

STANDARD SPECIFICATIONS

MODEL DESIGNATION CXU602

ENGINE: MACK MP8-415C

Peak Horsepower – 415HP at 1500-1700 RPM
Horsepower – 390 HP at 1950 Gov. RPM
Max. Torque – 1660 lb/ft at 1200 RPM
V-MAC IV – Total Vehicle Electronics
Air Compressor – Meritor/WABCO 318 (18.7 cfm)
Air Cleaner, 11" Single Element
Dry Type, Under Hood
Air Intake from Both Sides of Hood
Alternator, 12V 100A – Delco (24SI)
Batteries, (3) Mack 12V M/F Group – 650 CCA
Total 1950 CCA w/Kalas Cables
Coolant Protection - 34°F (-37°C)
Mack Coolant Conditioner
Diesel Particulate Filter – Vertical RH Side Back of Cab
Exhaust After Treatment System, Ceramic Catalyzed
Engine Brake – Mack Powerleash
Silicone Engine Hoses and Tubing
Poly-V Fan Belt w/Automatic Tensioner
Fan Drive, Electronically Modulated Type
Flywheel Housing, Aluminum
Fuel Water Separator
Mack EPDM Radiator & Heater Hoses
Aluminum Radiator
Starter, 12V Gear Reduction
Electronic Starter Interlock

CLUTCH: EATON/FULLER, CL798

15.5" Two-Plate w/Dampened Ceramic Coax
Manual Adjust
9-Spring 4-Paddle Driven Disc & 2" Diameter Spline

TRANSMISSION: FULLER, FRO-16210B

10-Speed, Ratios: 11.06 Low – 0.75 High
Driveline: Meritor 17N HD w/Coated Splines

CAB: CA68 CONVENTIONAL

Air Conditioner w/Integral Heater – R134a Refrigerant
Air Restriction Monitor, Graduated Lock Up Type
Air Cleaner Intake Mounted
Ash Tray
Cab Mounting
Four Point System w/2 Air Bags and Shocks at Rear
Cigar Lighter
Coat Hook (2)
Cup Holders, Driver's & Rider's Side
Dome Lights, 2 Lamps LH/ 2 Lamps RH
Doors, Galvanized Steel Visibility Doors
Engine Shutoff – Key Type Control
Floor Mats, Mack Signature Polyurethane
Air Pressure Gauge – Primary & Secondary
Voltmeter - Digital Gauge Cluster:
Exhaust Pryometer and Transmission Oil
Temperature Gauges
Engine Coolant Temperature Gauge
Engine Oil Pressure Gauge
Fuel Level Gauge
Speedometer, Electronic w/Trip Odometer
Engine Tachometer Electronic w/Hourmeter
Safety Tinted Windshield, Side and Rear Windows
Grab Handles, Black Finish RH & LH Behind Door
Horn, Air Horn Single Tone Electronic
Identification and Clearance Lights (5)

MACK

PINNACLE AXLE BACK 4X2 SERIES



- Conventional Cab
- Advantage Chassis
- Set-Back Front Axle
- 4-Wheel Tractor

The MACK Pinnacle Axle Back is for fleet owner and owner-operator alike, a total chassis optimized through computer-aided design for an excellent strength-to-weight ratio. The cab incorporates exceptional room and comfort with the highest standards of fit and finish. The cab ride is an innovative cab air suspension, for unsurpassed smoothness and comfort. The axle-back configuration contributes to handling ease, while the quiet roomy interior caters to the driver's every need.

STANDARD

ENGINE: MACK MP8-415C
415 HP [309 kW] Peak Horsepower

TRANSMISSION: FULLER, FRO-16210B
10-Speed

FRONT AXLE: MACK FXL12
12,000 lb. [5 443 kg] Capacity

REAR AXLE: MERITOR RS-23-161
23,000 lb. [10 433 kg] Capacity
Suspension: Multileaf Spring



STANDARD SPECIFICATIONS

(Continued)

CAB: CA68 CONVENTIONAL (Continued)

Instrument Cluster:
Segmented LCD Driver's Display
Instrument Panel, Charcoal Gray
Interior Trim: Genuine – Slate Gray
Keys, 2 – Keyed at Random
Low Air Pressure Indicator, Light and Buzzer
Exterior Mirrors, Body Colored Aero Mirrors
w/Integrated Convex Mirror
Parking Brake On Indicator Light
Radio Accommodation Package
Includes: Antenna, Power Supply and 2 Speakers
CB – 5 way Binding Post
Seating:
Driver – Bostrom Talladega 915 Mid-Back Air Suspension
Rider – Mack Fixed Mid-Back Non-suspension
Seat Belts, Lap and Shoulder w/Cab Mounted Shoulder Belt
w/Fixed D-Ring for Driver and Rider Seats
Side Markers – Lamps and Reflectors
Key Type Starter Switch
Steering Column, Adjustable Tilt Telescope
Steering Wheel, Two Spoke Urethane Grip Painted Spokes
and Bulldog Horn Cap
Overhead Console, 3 Storage Compartments w/Nets
Rear Storage Pouch
Sun Visor, Interior Both Sides w/Ticket Holder
Turn Signals, Integral w/Fender
Window Control, Standard Hand Crank
Windshield – 2 Piece
Windshield Washers, Wiper Mounted w/Reservoir
Mounted under Hood
Windshield Wipers:
2 Speed Electric Motor w/Intermittent Feature

HOOD & FENDERS:

One Piece Fiberglass w/Wheel Splash Aprons
SMC (Sheet Molding Compound)
Grille, Bright Finish Bars w/Black Background

FRAME:

Wheelbase (WB) – 150"
Load Platform (LP) – 125"
Cab to Axle (CA) – 84"
Axle to End of Frame (AF) – 41"
Frame Rails – Steel
Cross Section – 10.47" x 3.54" x .24"
Section Modulus, 11.6 in.³
RBM (per rail) – 1,390,000 lb. in.
Tapered and Flanged Rail Ends – 28°
Bumper: Stainless Steel Clad Aluminum Flush Mounted
Bumper to Back of Cab (BBC) – 116"
Fifth Wheel: Fontaine SL3ASB Air Slide
Front Towing, Clevis (2)

FUEL TANKS:

Capacity/Location: 93 Gallon LH & RH
Unpainted Aluminum, 26" Diameter

FRONT AXLE: MACK FXL12

12,000 lb. Capacity
Tires: 295/75R22.5 (Low Profile)
Wheel Equipment: (2) 22.5" x 8.25" Alcoa 10-Hole Hub Piloted
Aluminum Disc, 11¼" Bolt Circle
Brakes: Meritor "S" Cam 15" x 4" Q-Plus w/o Dust Shields
Shock Absorbers
Slack Adjusters – Automatic
Suspension:
Mack Taperleaf 12,000 lb. Ground Load Rating
2 Leaf Spring
Steering: TAS-65 Ross Integral Power Steering

REAR AXLE: MERITOR RS-23-161

23,000 lb Capacity
Carrier – Malleable Housing
Suspension – Mack Multileaf 23,000 lb Capacity
Tires: 295/75R22.5 (Low Profile)
Wheel Equipment: (4) 22.5x8.25 Alcoa 10-Hole Hub Piloted,
Aluminum Disc, 11¼" Bolt Circle
Brakes: Meritor "S" Cam 16.5" x 7" Q-Plus w/o Dust Shields
Wheel Seals – Oil
Slack Adjusters – Automatic
Spring Brake Chambers:
(2) 30/30 Double Diaphragm Type
Mechanical Spring Release

AIR/BRAKE:

Dual Air Brake System
Air Dryer – Meritor System Saver 1200P
Air Reservoirs – Steel 5600 in³ Capacity
Single Compartment Primary and Two
Compartment Supply/Secondary
Mack Road Stability Advantage System
Brake Control – 2 Valve Dual Brake System
Trailer Supply and Tractor-Trailer Park
Hand Control Valve for Trailer Brake
Trailer Connection Package: Semi
(2) 12' Air Hoses w/Integral Glad Hand Electrical Plug Holder
Storage Bracket
(1) 12' Seven Wire Cord w/Seven Wire Plug on Each End
Ground Reachable,
Breakaway Safety Valve
Conspicuity Treatment to Back of Cab

ELECTRICAL:

Battery Box – Steel w/Molded Plastic Cover
Mounted Left-hand side Under Cab
Courtesy Light Switch – Headlamp and Clearance
Daytime Running Lights
Doubles Trailer Electrical Package
Electric Circuit Protection Package
Waterproof Electrical Connections
Rear Lighting – (2) Combination Stop, Tail Directional and
Back-Up Lights
Headlights – Flush mounted Rectangular Halogen Lamps
w/Lexan Lens, Replaceable Bulbs
Transistorized Turn Signal Flasher

PAINT:

Cab, Hood and Fenders:
Mack White (High Gloss)
Urethane Base Coat w/o Clear Coat
Chassis Running Gear:
Mack Black (Urethane)

WEIGHT:

Font: 8,538
Rear: 3,684
TOTAL: 12,222

CHASSIS SPECIFICATIONS

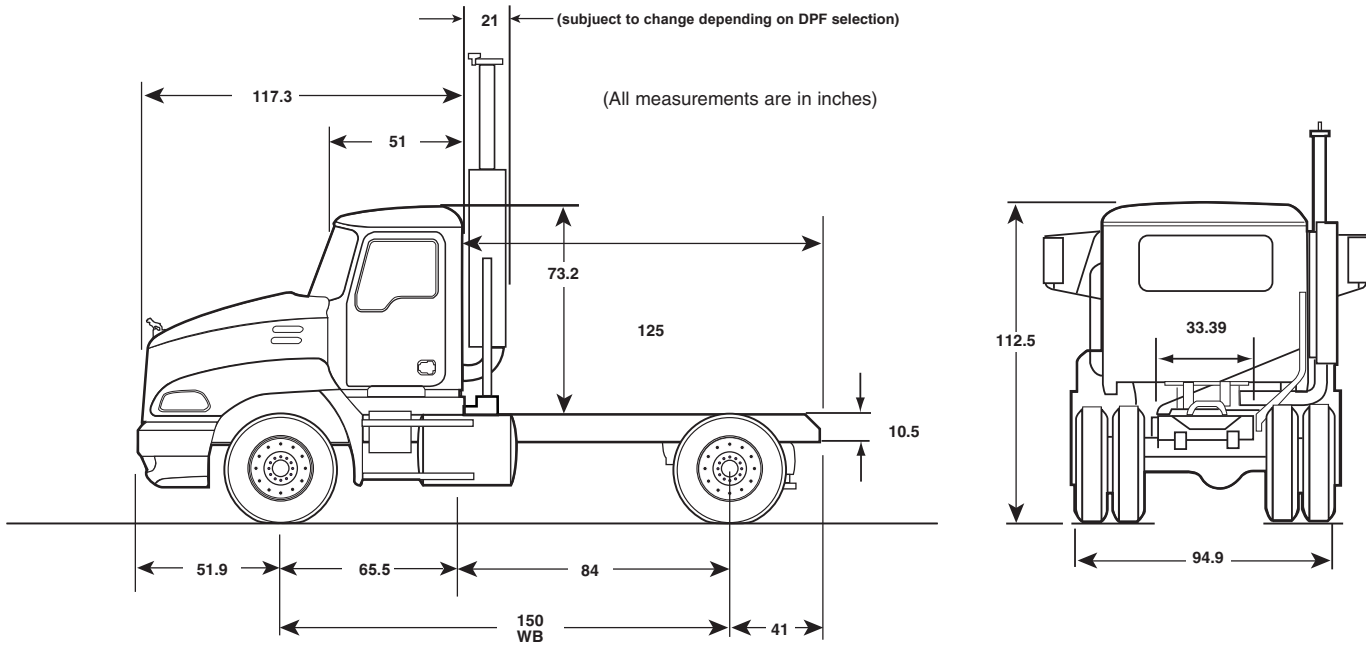

AVAILABLE DRIVE LINE COMPONENTS

MP7—ENGINES	
MODEL	HORSEPOWER
MACK	
MP7-325E	325 HP [242 kW] @ 1500-1800 RPM 325 HP [242 kW] @ 1800
MP7-355E	355 HP [265 kW] @ 1500-1800 RPM 355 HP [265 kW] @ 1800
MP7-405E	405 HP [302 kW] @ 1500-1800 RPM 405HP [302 kW] @ 1800
MP7-345C	345 HP [257 kW] @ 1500-1700 RPM 320 HP [239 kW] @ 1950
MP7-365C	365 HP [272 kW] @ 1500-1700 RPM 340 HP [254 kW] @ 1950
MP7-395C	395 HP [295 kW] @ 1500-1700 RPM 370 HP [276 kW] @ 1950

MP8—ENGINES	
MODEL	HORSEPOWER
MACK	
MP8-425E	425 HP [317 kW] @ 1500-1800 RPM 425 HP [317 kW] @ 1800
MP8-455E	455 HP [339 kW] @ 1500-1800 RPM 455HP [339 kW] @ 1800
MP8-485E	485 HP [362 kW] @ 1500-1800 RPM 485 HP [362 kW] @ 1800
MP8-415C	415 HP [309 kW] @ 1500-1700 RPM 390 HP [291 kW] @ 1950
MP8-445C	445 HP [332 kW] @ 1500-1700 RPM 420 HP [314 kW] @ 1950
MP8-485C	485 HP [362 kW] @ 1500-1700 RPM 455 HP [339 kW] @ 1950

TRANSMISSIONS		
MODEL	SPEEDS	RATIOS (LOW/HIGH)
MACK		
T306G	6	7.50/0.71
T309	9	11.40/0.71
T309(LR)	9	13.93/0.71
T310	10	13.81/0.73
T310M	10	17.35/0.73
T310ME	10	17.35/0.73
T313LR	13	16.42/0.71
T313	13	13.44/0.71
T318LR	18	16.42/0.71
T318	18	13.44/0.71
ALLISON		
4000-HS	5	3.51/0.74
4500-HS	5	4.70/0.76
4000-RDS	5	3.51/0.74
4500-RDS	5	4.70/0.76
4000-HS	6	3.51/0.64
4500-HS	6	4.70/0.67
4000-RDS	6	3.51/0.64
4500-RDS	6	4.70/0.64

AXLES		
CAPACITY	MAKE	MODEL
FRONT AXLES		
12,000 lb. [5 443 kg]	MACK	FXL12
	DANA SPICER	E1202I
	MERITOR	FF966
14,600 lb. [6 486 kg]	MACK	FXL14.6
	HENDRICKSON	STEERTEK
SINGLE REAR AXLES		
23,000 lb. [10 433 kg]	MACK	RA23R
	DANA SPICER	S23190
	MERITOR	RS-23-161/186

TRANSMISSIONS (Continued)		
MODEL	SPEEDS	RATIOS (LOW/HIGH)
EATON FULLER		
RTX-13609B	9	12.57/0.73
RTX-14609B	9	12.57/0.73
RTX-16709B	9	12.46/0.76
FRO-13210B	10	11.06/0.75
FRO-13210C	10	12.69/0.74
FRO-14210B	10	11.06/0.75
FRO-14210C	10	12.69/0.74
FRO-15210B	10	11.06/0.75
FRO-15210C	10	12.69/0.74
FRO-16210B	10	11.06/0.75
FRO-16210C	10	12.69/0.74
RTO-14908LL	10	14.56/0.74
RTO-16908LL	10	14.56/0.74
FR-13210B	10	14.80/1.00
FR-14210B	10	14.80/1.00
RTLO-14913A	13	12.31/0.73
RTLO-16913A	13	12.31/0.73
RT-14915	15	16.94/1.00
RTO-14915	15	13.31/0.79
RTO-16915	15	13.31/0.79
RTLO-14918B	18	14.40/0.73
RTLO-16918B	18	14.40/0.73
EATON FULLER-AUTO SHIFT		
RTO-16910B-DM3	10	10.96/0.74
RTO-14910B-DM3	10	10.96/0.74
RTO-14910B-AS3	10	10.96/0.74
RTO-14910C-AS3	10	12.80/0.73
RTO-16910B-AS3	10	10.96/0.74
RTO-14910C-AS3	10	12.80/0.73
RTLO-14918A-AS3	18	12.19/0.73
RTLO-16918A-AS3	18	12.19/0.73

OPTIONAL EQUIPMENT

FRAME:

Rail Dimensions: 10.47" x 3.54" x .28"
Section Modulus: 13.3 in.³
Resistance Bending Moment (RBM) 1,600,000 lbs. in.

Rail Dimensions: 10.47" x 3.54" x .32"
Section Modulus: 15.0 in.³
Resistance Bending Moment (RBM) 1,810,000 lbs. in.

Wheelbase Availability: 138" to 238"

CAB, OPTIONAL INTERIOR TRIM LEVELS:

Trim Level II – Custom: Refer to MackTraQ for complete description
Trim Level III – Grand Touring: Refer to MackTraQ for complete description

SLEEPER BOXES: Interior Color Matches that of the Cab Interior

48" Flat Top
56" Flat Top
60" Mid Rise
70" Mid Rise
70" High Rise

AERO AIDS:

Roof Fairings
Side Shields

OTHER OPTIONAL EQUIPMENT:

ABS Options	Hood Insulation
Aerodynamic Aids	Hubodometer
Air Dryer Options	Identification/Clearance Lights
Air Horns	In-Dash Storage
Air Reservoir, Aluminum	Instrument Panel Trim
Alternator Options	Keyed Alike Chassis
Back of Cab Reflectors	Keyless Entry
Back-Up Alarm	Metric Gauges
Batter Box Cover, Aluminum	Mirror Options
Battery Disconnect Switch	Mud Flaps
Battery Options	Overhead Console, 2 Compartments
Brake Equipment Options	Permit Plates
Bright Finish Exhaust	Personalized Name Plate
Bright Finish Fuel Tanks	Power Windows & Locks
Bug Screen	Push Button Start
Cab Window Options	Quarter Fenders
CB Radio Options	Reflector Kit
Coolant Protection	Seat Options, Driver & Rider
Co-Pilot Driver Information Display	Side Shield Extensions
Crossmember Options	Sliding Rear Window
Dash Mounted Switches	Starter Option
Door Interior Trim Panels	Steering Wheel Options
Dual Exhaust	Stereo Radio Options
Engine Block Heater	Storage Console
Engine Starting Aid	Sun Visor, Exterior
Fifth Wheel & Related Equipment	Synthetic Lubricants
Fire Extinguisher	Trailer Hook-Up Lamp
Fog Lights	Wheel Equipment Options
Fuel Heater	Wheel Lugwrench
Gauge Cluster Options	Windshield Curtain

The information in this brochure was accurate as known as of the date of the publication. Illustrations may not be representative of current product. Mack Trucks, Inc. reserves the right to make changes in specifications, equipment or design, or to discontinue models or options without notice at any time.