

DEFINING TOMORROW

K200



● K200

Introducing the new K200. With its stylish looks, greatly enhanced driver environment, improved cooling package, and increased safety, the best just got even better. The Kenworth K200 cab-over is the perfect choice when it comes to maximising your bottom line for B-Double applications. The K200 provides operators with exceptional power and flexibility, so you can haul bigger loads with greater ease. Suited to most Australian applications, the K200 is ideal for up to 26m B-Double and B-Triple combinations.



● ADR 80/03 - THE NEW AUSTRALIAN EMISSIONS STANDARD

For the K200 the emission solution employed to meet ADR 80/03 in the 2011 model range powered by Cummins ISX and Signature engines is cooled Exhaust Gas Recirculation (EGR).

Kenworth is introducing a Cummins Diesel Particulate Filter as part of the engine package. The Cummins Diesel Particulate Filter, which replaces the existing vehicle muffler, reduces particulate emissions by 90% from ADR80/02 levels and is designed to last the life of the engine.

Kenworth's application engineering process has delivered an optimised solution that integrates integrate EGR seamlessly across the high horsepower engine options. So as well as being highly efficient and low maintenance the EGR emission solution has impact on payload. Kenworth customers get the emission compliance they need with the proven performance and reliability of engines they know and trust - all with the back up of our renowned local design and manufacturing capability and Australia wide support network.

● EBSS - ELECTRONIC BRAKE SAFETY SYSTEM

At Kenworth, safety has always been a paramount consideration, and we continue to invest heavily in developing a safer working environment for road transport operators and other road users. All 2011 new model Kenworth's will be available with the latest Kenworth EBSS Safety Package. EBSS incorporates a variety of safety features including ABS, Drag Torque Control, Traction Control and ESP.

Kenworth EBSS has been designed to provide a class leading and reliable system for Australasia's unique road conditions and applications, and deliver better peace of mind for all road users. To learn more about these safety systems visit www.kenworth.com.au

ENHANCED DRIVER ENVIRONMENT



NEW STYLING



IMPROVED ACCESS



K200 1.7M FLAT ROOF

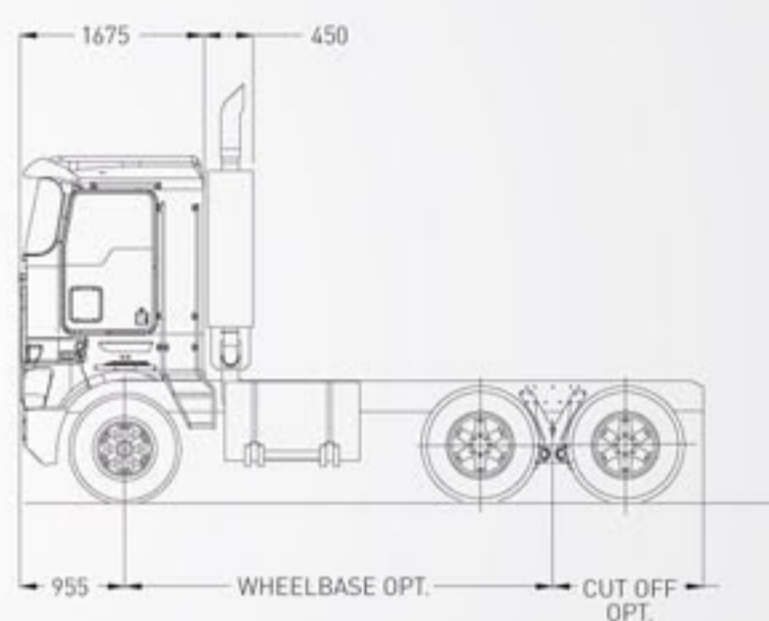

K200 2.3M AERODYNE

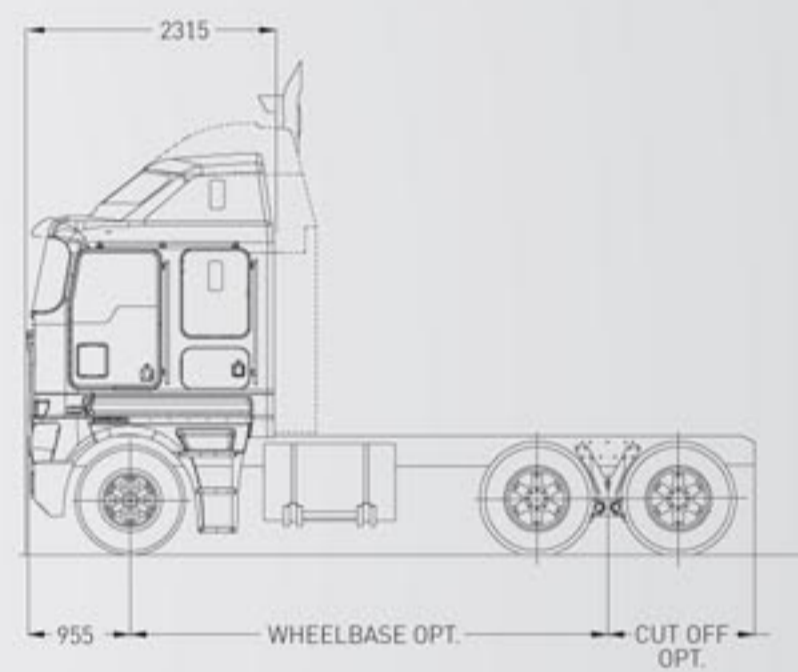

K200 2.8M AERODYNE

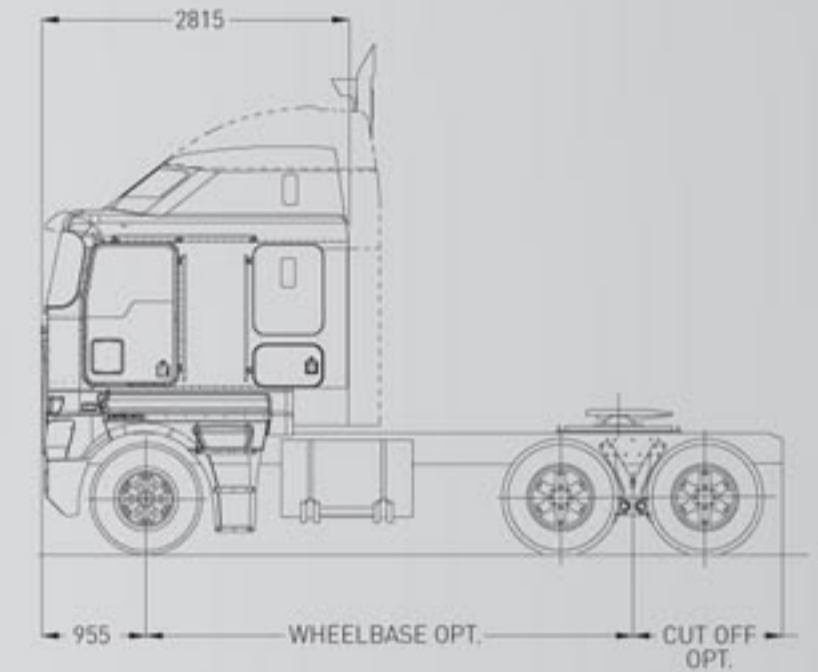

MAIN SPECIFICATIONS AND OPTIONS

CONFIGURATION

- 6X4 **standard**
- 8X4 **optional**
- 8X6 **optional**
- 10X6 **optional**

KITS

- FUEL HAUL & GAS HAUL **optional**

ENGINE

- ISX EGR 485HP @ 1650 LBFT TORQUE **standard**
- ISX EGR 485HP @ 1850 LBFT TORQUE **optional**
- ISX EGR 500HP @ 1850 LBFT TORQUE **optional**
- ISX EGR 525HP @ 1850 LBFT TORQUE **optional**
- ISX EGR 550HP @ 1850 LBFT TORQUE **optional**
- ISX EGR 600HP @ 1850 LBFT TORQUE **optional**
- SIGNATURE 600HP @ 2050 LBFT TORQUE **optional**

EXHAUST

- DPF POST MOUNTED VERTICAL RIGHT HAND SIDE **standard**

AIR CLEANER

- DONALDSON 2501 AIR CLEANER MOUNTED UNDER CAB **standard**

TRANSMISSION

- UP TO EATON RTLO22918A-AS3 **optional**
- EATON RTLO16918B **standard**
- EATON RTLO18913A **optional**
- EATON RTLO18918B **optional**
- EATON RTLO20918B **optional**
- EATON RTLO22918B **optional**

ULTRASHIFT PLUS OPTIONS

- FO - 16E318B - MXP
- FO - 18E318B - MXP
- FO - 20E318B - MXP
- FO - 22E318B - MXP

FRONT AXLE

- DANA E-1462I **standard**
- MERITOR FG941 **optional**
- MERITOR twin steer FG941 **optional**

REAR AXLE

- DANA DSH40P **standard**
- DANA D46-170 **optional**
- DANA D50 -170 **optional**
- DANA D52-190 **optional**
- MERITOR RT40-145 **optional**
- MERITOR RT46-160 **optional**
- MERITOR RT52-185 **optional**
- SISU FR2P-32 **optional**
- SISU FR3P-48 **optional**

REAR SUSPENSION

- KENWORTH AIRGLIDE 400 **standard**
- KENWORTH AIRGLIDE 460 **optional**
- KENWORTH KW6-60A **optional**
- NEWAY AD246/10 **optional**
- NEWAY AD369/10 **optional**

BRAKES

- DRUM **standard**
- DISC **optional**

WHEELS

- 6 SPOKE **standard**
- ALCOA 10 STUD **optional**

CAB

- 1.7M FLAT ROOF **optional**

SLEEPER

- 2.3M FLAT ROOF **standard**
- 2.3M AERODYNE **optional**
- 2.8M AERODYNE **optional**

FUEL TANKS

- 350L 725MM DIA FUEL TANK RIGHT HAND REAR **standard**
- RANGE OF PACKAGES AVAILABLE **optional**

PAINT

- SINGLE COLOUR TO CAB **standard**
- UP TO 3 COLOURS 6 BREAKS **optional**

GCM

- 90 TONNE LIMIT*



* higher rating subject to application approval

THE BEST DEALER NETWORK

Kenworth has built an extensive truck dealer network across Australia that is renowned for its professionalism and excellence in the heavy duty truck industry. The Kenworth dealer network also includes highly qualified dealers in New Zealand and Papua New Guinea.



For more information contact your local Kenworth Dealer or go to www.kenworth.com.au

IMPORTANT: The vehicles shown in this brochure are for illustrative purposes only and may include some non-standard optional equipment. All weights and measurements should be regarded as approximate only. For full details contact your Kenworth Dealer. In the interests of product improvement, Kenworth reserves the right to change these specifications without prior notice.

PACCAR Australia Pty Ltd,
64 Canterbury Road, Bayswater, Victoria 3153

Telephone (03) 9721 1500
Facsimile: (03) 9720 4144

PACCAR



PACCAR FINANCIAL