

KENWORTH K500

Heavy Duty Chassis



A DIVISION OF **PACCAR**

The K500 is a combination of the C500 drivetrain with a modern, PACCAR COE cab. This configuration addresses the need for an on/off-highway vehicle with improved visibility and more cab space than provided by conventional models. The resulting unit is a shorter, more maneuverable truck or tractor with the mobile off-highway characteristics that make this Kenworth highly desirable, whatever the application.

Kenworth K500 Specifications*

* Specifications subject to Kenworth Applications Engineering approval

ENGINE AND ENGINE EQUIPMENT

Cummins ISX or Caterpillar C13 or C15 engines.

24 V electrical system

4 heavy duty batteries

Capable of meeting high ambient stationary cooling requirements.

MAIN TRANSMISSION & CLUTCH

Manual or Automatic transmissions

Transfer cases and PTO provisions available

Heavy duty driveline series

FRONT AXLE & EQUIPMENT

Non-drive front axle: from 20,000 lbs (9,071 kg) up to nominal 26,000 lb (11,793 kg) capacity w/ slipper springs and radius (torque) rods.

Driving front axle: from 22,000 lbs (9,979 kg) up to nominal 30,000 lb (13,607 kg) capacity w/ slipper springs and radius (torque) rods.

Optional twin-front axles available.

Dual power steering with cooler.

REAR AXLE & EQUIPMENT

Rear tandem axle: from 46,000 lbs (20,865 kg) up to nominal 85,000 lb (38,555 kg)

Rear tridem axle: from 58,000 lbs (26,308 kg) up to nominal 105,000 lb (47,626 kg)

Wide range of axle ratios available subject to application.

Beam, Air or Spring Suspensions.

Axle spacing to accommodate specified tires.

TIRES, WHEELS or RIMS

Commonly specified tires include: 315/80R22.5, 445/65R22.5, 14R20, 16R20, 24R21 with compatible wheels or rims.

FRAME & EQUIPMENT

High strength, heat-treated frame rails with up to two inserts to meet RBM and section modulus requirements.

Heavy Duty steel box bumper with cast center-mounted tow hook.

Steel battery box .

FUEL TANK

Standard capacity 100 Gal. (379 L); other capacities available.

Steel or aluminum tanks available.

CAB & EQUIPMENT

Spacious sleeper cab with advanced styling and finish. Steel construction incorporating severe service options.

Left and right-hand drive configurations available.

Cab suspension with integrated shock absorbers.

Heater/air conditioner

Comfort Air driver and passenger seats.

Kenworth AM/FM/cassette radio with clock

MISCELLANEOUS OPTIONS

A broad range of options are available. Contact your local Kenworth dealer to discuss your requirements.

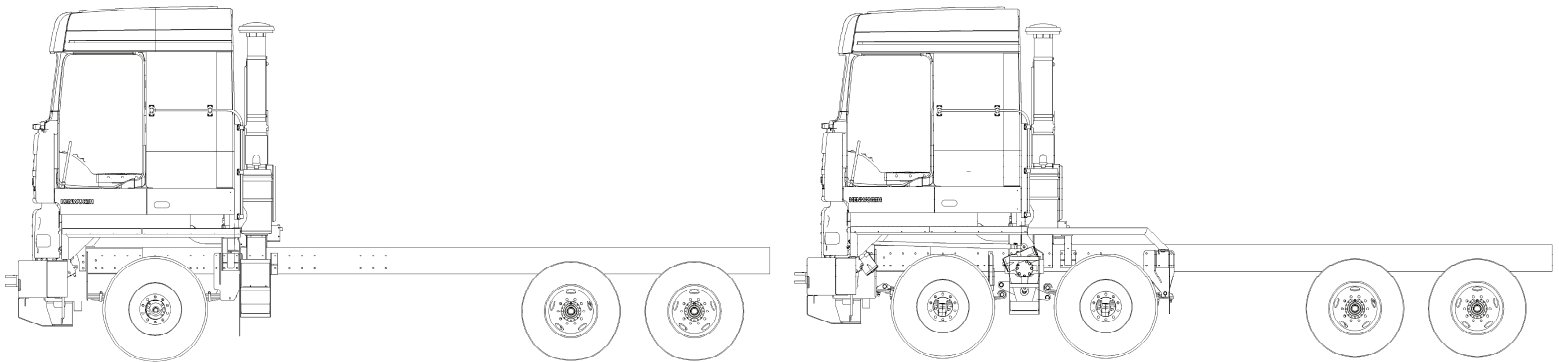

PACCAR International
A DIVISION OF PACCAR

PACCAR International

P.O. Box 1518

Bellevue, Washington 98009-1518, USA

Phone: (425) 468-7800, Fax: (425) 468-7580