

**BREMACH T-REX 4x4
SINGLE CAB**



The new BREMACH vehicle is made with a cell of adaptive modular space frame. This frame is built up by tubular profiles which are worked in 3 dimensions in section to create a complex structure fitted out with a torsional resistance never achieved before on current vehicles.

Based on a modular and lightness concept, this frame has the particularity of being specular at 360 degrees, and enables customer to create various models, Keeping high the resistance.

On this frame, ever at sight, are applied PMMA ABS panels built-in the mass that reduced the weight of the vehicle and gives an original shape to the frame.

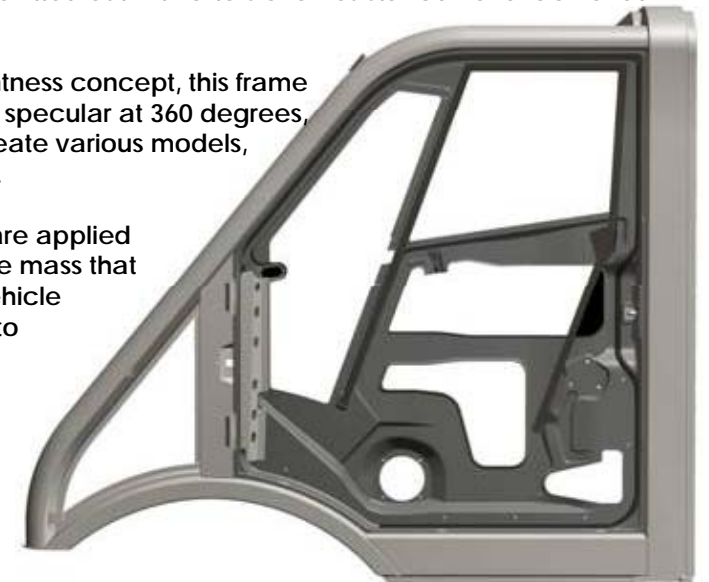

The behind-engine-type cab, is made by a galvanized sheet steel frame, a space-frame of high structural strenght. Fully treated with cataphoresis, for best protection against rust and corrosion, it is linked to the chassis with flexible plugs which filtrate the vibrations sent by mechanical organs in motion. The doors, with large windows, are made by galvanized steel of high structural strenght, and fully treated with cataphoresis. It can takes 3 people with single seats, and it is equipped with mechanical sprung seats (adjustable weight); the central one is fixed and its folding back can be used as table; all fitted headrest. Safety belt anchored to the bodywork of the floor and provided with rolling-up system, for the return to rest position.

The dashboard, made of shock-resistant and antireflection material, is provided with complete controlling instruments.

Conditioning plant allows wide use of ventilation, heating and air-conditioning thanks to the 4 speeds ventilator. Defrosting, ventilation, central/frontal and foot heating, is assured by openings on dashboard. Rudder bar/wheel/seat position allows driving up to 95 percentile (European rules).

Cab soundproofing, for the internal acoustic comfort, is assured by sound absorbent and thermoacoustic panels adequately set out in the cab and engine compartment.

Doors equipped with electrical sliding windows, automatic locks; big diametral steering wheel, spokes set for an easier reading of flange instruments; suitable grasp for handy use of the vehicle; overhead light with reading spotlight, complete the standard inner equipment.



Curved windscreen in rolled crystal reinforced, glued.

Door cab with tempered glass

Cab floor synthetic-covered

Foot boards and external handles assures easy access to the cab..

•Radio car with loudspeaker arrangement

Tubular front bumper with anterior indicator and fog lights integrated

Diagnosis check point



FPT F1AE0481G, 2.3 I
 4 cylinder turbodiesel, 16 valves
 Diesel four-stroke cycle,direct injection with waste gate
 Intercooler + EGR
 Group injection Common Rail Unijet 2nd generation
 Water cooling with impeller electromagnetic clutch
 Cast iron engine-block.
In line with 2006/51 Euro 4 CEE

POWER: 85KW (116HP) at 3900rpm
TORQUE: 270Nm a 1800rpm
BORE AND RUNNING: 88 x 94 mm



F1A



FPT F1CE0481G, 3.0 I
 4 cylinder turbodiesel, 16 valves
 Diesel four-stroke cycle,direct injection with waste gate
 Intercooler + EGR
 Diesel particulate filter(FAP)
 Group injection Common Rail Unijet 2nd generation
 Water cooling with impeller electromagnetic clutch
 Cast iron engine-block.
In line with 2006/51 Euro 4 CEE

POWER: 107 KW (146HP) a 3500 rpm
TORQUE: 350 Nm a 1800 rpm
BORE AND RUNNING: 95.8 x 104 mm

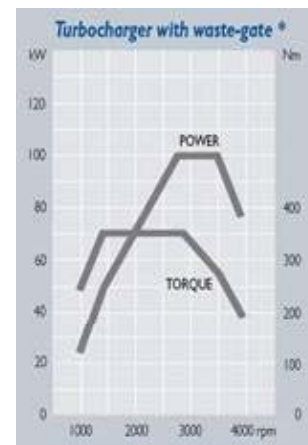

F1C



4 cylinder turbodiesel, 16 valves
 Diesel four-stroke cycle, variable Intercooler + EGR
 Diesel particulate filter(FAP)
 Group injection Common Rail Unijet 2nd generation
 Water cooling with impeller electromagnetic clutch
 Cast iron engine-block.
In line with 2006/51 Euro 4 CEE

POWER: 130 KW (176HP) a 3500 rpm
TORQUE: 400 Nm a 1800 rpm
BORE AND RUNNING: 95.8 x 104 mm

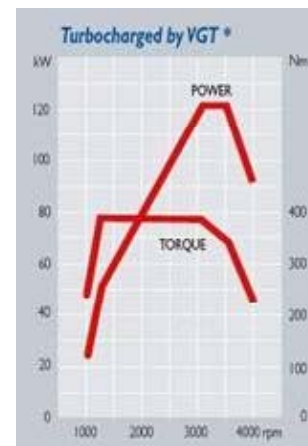

F1C*

*verificare con BREMACH la conformità omologativa relativa al mercato di riferimento

CLUTCH

Flat single-plate with hydraulic control. External diameter 11" (280mm), on F1C. Hydraulic disengagement pedal

GEAR BOX

The 6 speeds, together with Bremach reducer, allow to operate on every terrain. Sturdiness and easy use are guaranteed by ZF experience.

Synchronised, ZF S-300- 6 speed + REV (F1A engine)

- 1° 1:6,72
- 2° 1:3,94
- 3° 1:2,55
- 4° 1:1,77
- 5° 1:1,29
- 6° 1:1,00
- R 1:6,05



Synchronised, ZF S-300- 6 speed + REV (F1A engine)

- 1° 1:5,37
- 2° 1:3,15
- 3° 1:2,04
- 4° 1:1,36
- 5° 1:1,00
- 6° 1:0,79
- R 1:4,84

DRIVE LINE

Permanent four-wheel drive with the 3rd central differential lockable as standard equipped.
Torque distribution: 33% front axle - 67% rear axle (50-50 with 3rd central differential locked)
All differential locks and transfer box are hydraulically controlled
Ratio at the axles: 10/45 (4.5) or 9/46 (5.1)



All the above-shown devices can be easily operated from the driver seat with relevant key placed in the dashboard

BK 20- 2 RATIO BREMACH TRANSFER BOX
3 shafts with gear/reduced oil-pressure includes the epicycloidal central differential

	GEAR BOX RATIO	REDUCER RATIOS "SPEEDY" BK10		REDUCER RATIO "SLOW" BK10		RATIO AT THE AXLES
		GEAR	REDUCED	GEAR	REDUCED	
ZF S380 Meccanico	1° 5,37 : 1	GEAR	REDUCED	GEAR	REDUCED	4,5 o 5,1
6 Avanti + 1 RM	6° 0,79 : 1	1 : 1,03	1 : 3,09	1 : 1,30	1 : 3,90	

RIDUTTORE BREMACH BK20 a 4 rapporti (OPTIONAL)
BK20 4-RATIO BREMACH TRANSFER BOX
3 shafts with on/off-road oil-pressure control. It joins the epicycloidal central differential

SPEED RANGES AS A FUNCTION OF THE RATIO (ratio 4.5, tyres 225/75 R17.5, speed 1000-3900rpm):

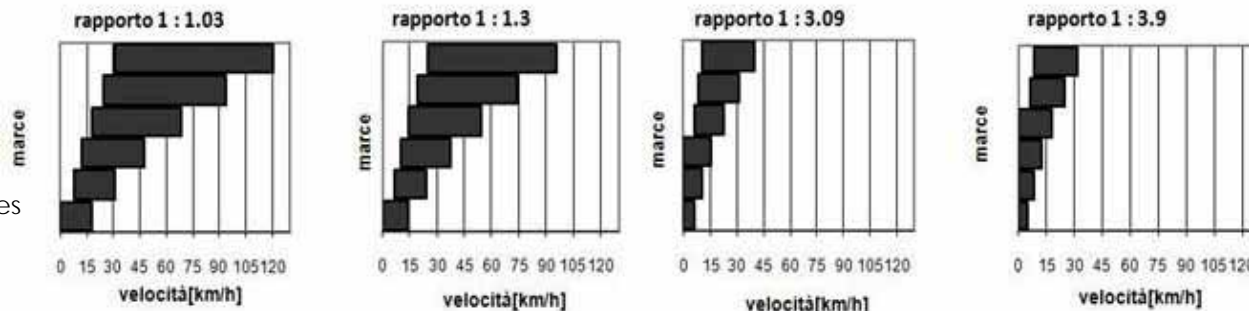

CHASSIS

Bearing-type frame, with two longitudinal frame rails, joined by two welded cross members, forming a solid and compact structure, that can stand the heavy stress it will be subject to in operation. Sandblasted before being painted, in order to assure a proper protection against corrosion.
The section of the main frame member is made of a closed tube lengthwise welded to a C-type profile, in order to assure the max torsional and flexural strength.

BRAKES

Independent double hydraulic circuit, with brakes on four wheels and autoventilating on the front one, standard ABS on all versions.

IVECO-BREMBO brakes disks. Phonic wheels and the whole anti-blocking system are specifically engineered and designed by BREMACH in collaboration with BOSCH, that tested their merits, for the extreme use of the vehicles on- and off-road; the ABS gearcase, indeed, is steadily connected with a specific longitudinal deceleration sensor, particularly sensitive to unusual conditions the vehicles undergo.

Brakes disks dimensions:

Front: 290mm diameter , 26mm lining, autoventilating

Rear: 306mm diameter, 33 mm lining

Mechanic parking brake on the rear wheels

SUSPENSIONS

Rigid axles with parabolic leaf-spring of 1250mm lenght, telescopic double-acting shock-absorbers, and properly dimensioned front and rear stabilising bars for an easier driving on and off road.

WHEELS

As standard: Iron rims 17,5" with pass 6" Tyres 225/75 R17,5 (su 3.5t), 245/70 R17.5 (su 6.0t)

Optionals: Iron rims 16 " with pass 6.5"

MICHELIN XZL 255/100 R16 with off-road plugging (on 3.5t and 6.0t)

STEERING

Hydraulic power assisted. Wheel diameter 410mm.

Steering-column in 3 trunks with joint connection cardans .

Anti-theft - steering lock

ELECTRICAL EQUIPMENT

12V equipment with prearrangement for double accumulator and seven-pole socket for trailers, 140A alternator and 100Ah battery.

Starter motor: 2.2kW

Electricity collection points: from battery junction box to the engine compartment.

2 connectors inside the cab

POWER TAKE-OFF (PTO)

AT GEARBOX: flange arrangement on the left side of the gearbox. Maximum torque 180Nm at 1500 rpm.

AT REDUCER: flange assembly arrangement on the rear side of the reducer. Maximum torque 150Nm at 1900 rpm.

CONTROLS

- cooling liquid temperature gauge (with max temperature warning light)
- low fuel warning light
- warning light for sidelights
- warning light for high lights
- warning light for low battery charge
- engine oil pressure warning light
- handbrake warning light
- warning light refraining system
- warning light for turn indicators
- water into fuel filter warning light
- 3-way tipper warning light
- PTO at the engine warning light
- PTO at the gear
- four wheel drive warning light
- front differential locking warning light
- rear differential locking warning light
- tow turn indicators warning light
- warning light emergency
- warning light rear fog
- warning light for ABS defect
- warning light for OBD defect
- warning light for diagnostics
- warning light for preheating



WARNING LIGHTS

- Electronic tachometer/speedometer (with the possibility of double scale km and mile)
- electronic revolution counter
- digital clock
- windscreen wiper control (3 speeds) – windscreen washer
- emergency light switch
- sidelights – low beam
- rear fog – guard switch
- heating fan switch
- headlight switch
- heating/defrosting control
- switches for electrical power side windows
- high lights switch
- turn indicator light control
- Lighters
- presetting to control – switch 3-way tipping body
- presetting to control – blinking light switch
- presetting to control – work light switch
- presetting to control – rear fog light
- presetting to control – siren switch / PTO at engine electric socket
- conditioned air switch
- RPM switch
- addition/reduction of engine revolution switch
- automatic selector for 1500 engine revolution
- warning signal switch
- connector for diagnostics
- Digital tachograph (on 6.0t versions only)



MASS AND DIMENSIONS

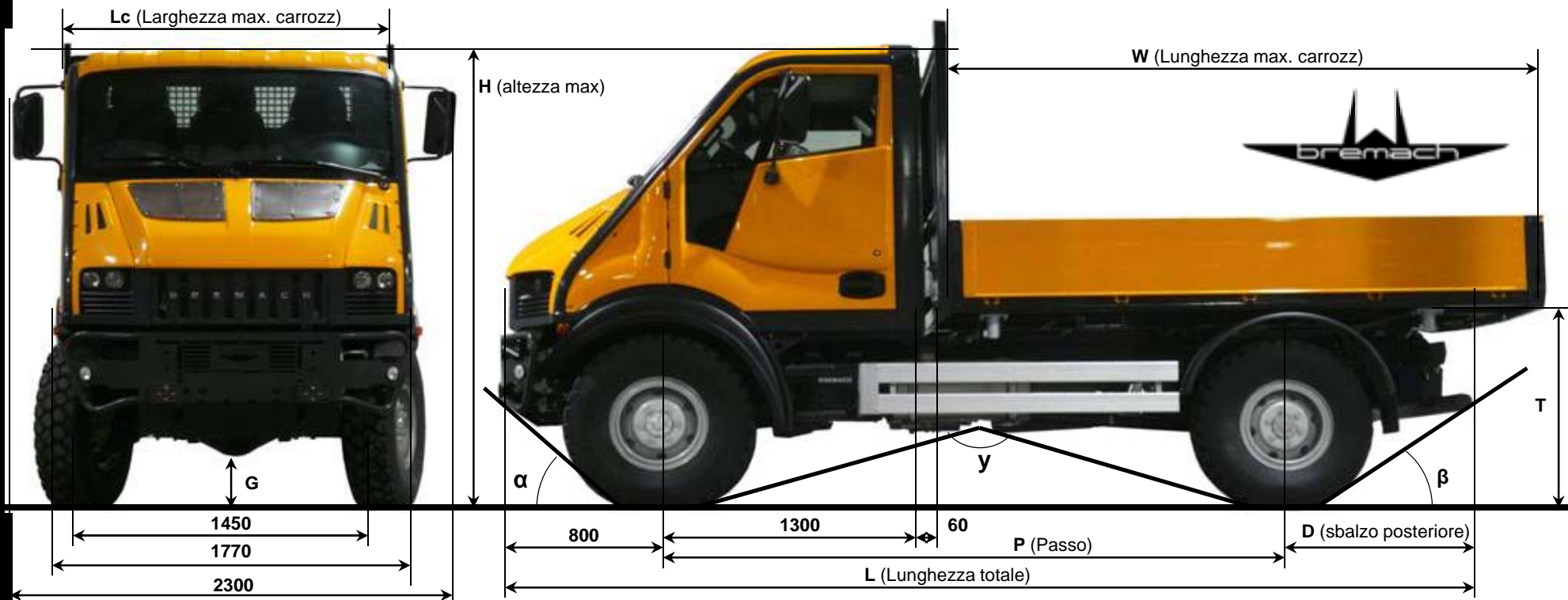

Gross vehicle weigh	3500	3500	3500	3500	6000	6000	6000	6000	6000	6000
Wheel/Tyres	on-road	225/75R17.5	off-road	255/100R16	on-road		245/70R17.5	off road		255/100R16
Wheelbase	2600	3100	2600	3100	2600	3100	3450	2600	3100	3450
L Max length	4380	4880	4380	4880	4380	4880	5230	4380	4880	5230
H Max height (unloaded)	2430	2425	2495	2490	2445	2435	2430	2505	2500	2495
Frontal wheel track	1440	1440	1465	1465	1440	1440	1440	1465	1465	1465
Rear wheel track	1455	1455	1485	1485	1455	1455	1455	1485	1485	1485
T Chassis height (unloaded)	915	910	980	975	955	950	948	1015	1010	1008
D Rear overhung	980	980	980	980	980	980	980	980	980	980
W max equipment length	2620	3120	2620	3120	2620	3120	3470	2620	3120	3470
Lc* Max width	1900	1900	1900	1900	1900	1900	1900	1900	1900	1900
Max load at front axle	2000	2000	2000	2000	2300	2300	2300	2300	2300	2300
Max load at rear axle	2500	2500	2500	2500	4450	4450	4450	4200	4200	4200
Cab tare at fron axle	1550	1572	1570	1592	1565	1587	1597	1585	1607	1617
Cab tare at rear axle	815	825	835	845	1010	1020	1025	1030	1040	1040
Total tare	2365	2397	2405	2437	2575	2607	2622	2615	2647	2657
Payload	1135	1103	1095	1063	3425	3393	3378	3385	3353	3343

Chassis equipped with F1A engine* OPT omologato:con specchi cat. II app. e3 03*2115 est 01 (braccio largo) Wmin/max = 2050 mm

PERFORMANCES

Gross vehicle weigh	3500	3500	3500	3500	6000	6000	6000	6000	6000	6000
Wheel	on-road	225/75R17.5	off road	255/100R16	on-road	245/70R17.5		off road	255/100R16	
Wheelbase	2600	3100	2600	3100	2600	3100	3450	2600	3100	3450
Max slope surmountable	100%	100%	100%	100%	100%	100%	100%	100%	100%	100%
α Front approach angle	45	45	48	48	45	45	45	48	48	48
Y Max summit angle		136	141	136	141	140	145	147	135	140
β Rear approach angle*	28 / 37	28 / 37	33/43	33 / 43	29 / 38	29/ 38	29/38	34/44	34 / 44	34 / 44
Max fording depth	750	750	800	800	750	750	750	800	800	800
G Axle height **	215 / 230	215 / 230	280 / 295	280 / 295	215 / 235	215 / 235	215 / 235	280 / 295	280 / 295	280 / 295

* on road / off road ** front / rear



OFF-ROAD PERFORMANCES

- 6.0 T T-REX wheelbase 2600mm
- Max summit angle 135°
- Max. slope surmountable 45°
- Front approach angle 48°
- Rear approach angle 44°
- Max fording depth 800mm
- Fording depth with preparation 900mm

