

PROFESSIONAL 827

CAB TYPE	Sleeper cab, high roof, twin bunk
CHASSIS FRAME USAGE	Tractive unit (YCB)
AXLE CONFIGURATION	6 x 4
ENGINE	
MAKE/MODEL	CUMMINS C8.3-260 (Euro-1)
TYPE	Turbo intercooler, diesel
NUMBER OF CYLINDERS	6
TOTAL DISPLACEMENT	8,268 lt
MAXIMUM POWER	263 PS (194 kW)@2200 rpm
MAXIMUM TORQUE	950 Nm (96.8 kgm)@1500 rpm
FUEL SYSTEM	
FUEL INJECTION PUMP MAKE	BOSCH
MODEL	In line type (P 7100)
FUEL TANK CAPACITY	230 lt
CLUTCH	
TYPE	Helical springs, twin ceramic disc, air assisted, hydraulic
DRIVEN PLATE DIAMETER	350 mm (14 inch)
GEAR BOX	
MAKE/MODEL	ZF 9S-109
NUMBER OF GEARS	9 forward, 1 reverse synchromesh,
FRONT AXLE	"I" section, forged steel, 7000 kg capacity
REAR AXLE	
MAKE/TYPER	ZF/APB35/DKZ, APB35/DK
NUMBER OF SPEEDS	Single speed, hub reduction
AXLE RATIO	6.03:1
CAPACITY	26000 kg
STEERING BOX	
MAKE/MODEL	HEMA (ZF)/8098
TYPE	Servocom, hydraulic
BRAKE SYSTEM	Dry type full air service brake, air actuated spring hand brake, exhaust brake, trailer brake
SUSPENSION	
FRONT AXLE	Semi-elliptic leaf spring, shock absorbers
REAR AXLE	Tandem leaf spring
ANTI-ROLL BAR	Front
CHASSIS FRAME	□ section steel profile □ section steel profile (inside)
TYRES	315/80 R 22.5, 10 + 1 items
RIMS	9.00 x 22.5, 10 studs
ELECTRICAL SYSTEM	
VOLTAGE	24 V, negative (-) ground
BATTERIES	2 x 12 V, 150 Ah
ALTERNATOR	24 V, 45 A
STARTER MOTOR	24 V, 7.8 kW

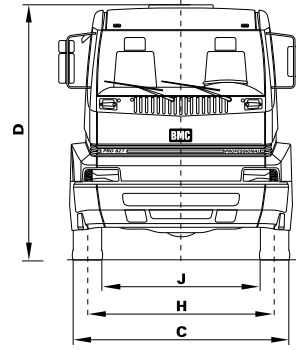
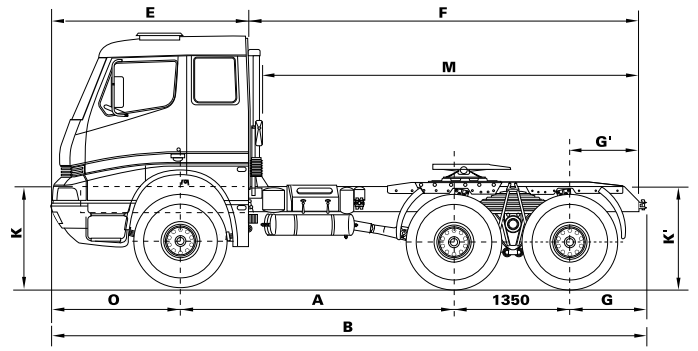

DIMENSIONS (mm)

A : Wheelbase	3200
B : Overall length	6985
C : Overall width	2500
D : Overall height	2770
E : Bumper to back of cab	2335
F : Back of cab to end of frame	4520
G : Rear overhang	930
G' : Chassis rear overhang	800
H : Front track	2055
J : Rear track	1828
K : Frame height on front axle	1100
K' : Frame height on rear axle	1130
M : Useful chassis length	4325
N : Frame width-front	975
N' : Frame width-rear	800
O : Front overhang	1505
P : King-pin height	1390

WEIGHTS (kg)

Kerb weight, total	9050
Capacity (including body)	34780
Maximum permissible total weight, front	7000
Maximum permissible total weight, rear	19000
Gross combination weight	43830

PERFORMANCE

Gradeability, tan (AS GVW) (%)	29
Maximum geared speed (kph)	70.4

JULY 26, 2001

The manufacturer reserves the right to modify design and specifications without prior notice.



GENERAL MANAGEMENT & FACTORY: Kemalpaşa Caddesi No: 32 35060 İzmir - TURKEY Tel: (90-232) 479 20 00 Fax: (0232) 479 13 64 - 479 12 88
E-Mail: fabrika@bmcsan.com • [http:// www.bmcsan.com](http://www.bmcsan.com)
SALES (EXPORTS) & SERVICE: Kemalpaşa Caddesi No: 32 35060 İzmir - TURKEY Tel: (90-232) 479 18 70 (PBX) Fax: (0232) 479 08 48
E-Mail: satis@bmcsan.com
U.K. OFFICE: Havenfields, Aylesbury Road, Great Missenden Bucks HP 16 9 LS ENGLAND Tel: (44) 1494-89 08 88 Fax: (44) 1494-89 08 84