

PROFESSIONAL

832



PROFESSIONAL 832 FDB (6X4)

CAB TYPE	Day cab
CHASSIS FRAME USAGE	Tipper
WHEEL CONFIGURATION	6 x 4
ENGINE	
MAKE/MODEL	Cummins C 300 20 (Euro 2)
TYPE	Turbo intercooler, diesel
NUMBER OF CYLINDERS	6
TOTAL DISPLACEMENT	8.3 lt
MAXIMUM POWER	300 PS (221 kW) @ 2200 rpm
MAXIMUM TORQUE	1125 Nm @ 1400 rpm
FUEL INJECTION	
MAKE/MODEL	Bosch/In line type
FUEL TANK CAPACITY	230/300 lt
CLUTCH	
TYPE	Helical springs, twin dry disc, air assisted hydraulic
DRIVEN PLATE DIAMETER	350 mm (14")
GEAR BOX	
MAKE/MODEL	ZF 9 S 109 DT
NUMBER OF GEARS	9 forward synchromesh, 1 reverse
FRONT AXLE	
TYPE, CAPACITY	"I" section forged steel, 7000 kg
REAR AXLE	
MAKE/TYPE	BMC 300T/300TC
NUMBER OF SPEEDS	Single speed, hub reduction
AXLE RATIO	6,03:1
CAPACITY	26000 kg
STEERING SYSTEM	
STEERING BOX MAKE/MODEL	Hema (ZF) 8098 Servocom
TYPE	Integral type, hydraulic
BRAKE SYSTEM	
	Full air service brake, air actuated spring parking brake (Opt. ABS/ASR)
SUSPENSION	
FRONT AXLE	Semi-elliptic leaf spring + telescopic shock absorbers
REAR AXLE	Tandem leaf spring
ANTI-ROLL BAR	Front
CHASSIS	
PROFILE TYPE	"C" section steel profile
REINFORCEMENT TYPE	"C" section, inner flitch, steel profile
TYRES	315/80 R 22.5, 10 + 1 tubeless
RIMS	9.00 x 22.5, 10 studs
ELECTRICAL SYSTEM	
VOLTAGE	24 V, negative (-) ground
BATTERIES	2 x 12 V, 150 Ah
ALTERNATOR	70 V
STARTER MOTOR	24 V

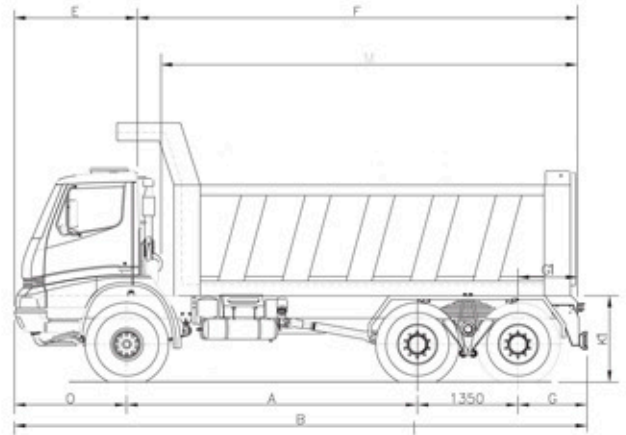

DIMENSIONS (mm)

A: Wheelbase	3900
B: Overall length	7685
C: Overall width	2500
D: Overall height	2870
E: Bumper to back of cab	1696
F: Back of cab to end of frame	5859
G: Rear overhang	930
G1: Chassis rear overhang	800
H: Front track	2070
J: Rear track	1838
K: Frame height on front axle	1100
K1: Frame height on rear axle	1130
M: Useful chassis length	5664
N: Frame width-front	975
N1: Frame width-rear	800
O: Front overhang	1505

WEIGHTS (kg)

Kerb weight	9100
Kerb weight, front axle	4020
Kerb weight, rear axle	5080
Payload (including body)	23900
Max. permissible total weight, front	7000
Max. permissible total weight, rear	26000 (13000+13000)
Gross vehicle weight	33000

PERFORMANCE

Gradeability (at GVW) (%)	>35
Max. geared speed (km/h)	70

GENERAL MANAGEMENT & FACTORY: Kemalpaşa Caddesi No: 32 35060 İzmir-TURKEY **Tel:** (+90 232) 477 18 00 **Fax:** (+90 232) 477 18 77
 477 18 78-477 18 79 **Web Site:** www.bmc.com.tr **EXPORT SALES:** Kemalpaşa Caddesi No: 32 35060 İzmir-TURKEY **Tel:** (+90 232) 477 18 00 (PBX)
Fax: (+90 232) 477 18 33 **E-Mail:** exportsales@bmc.com.tr **UK OFFICE:** Havenfields, Aylesbury Road, Great Missenden Bucks HP 16 9 LS ENGLAND
Tel: (+44) 1494-89 08 88 **Fax:** (+44) 1494-89 08 84 **E-Mail:** bmc.uk@btinternet.com

The manufacturer reserves the right to modify design and specifications without prior notice.

