

PROFESSIONAL

935



PROFESSIONAL 935 FTB (6X4)

CAB TYPE	Day Cab
CHASSIS FRAME USAGE	Transmixer
WHEEL CONFIGURATION	6x4
ENGINE	
MAKE/MODEL	Cummins ISLe+ 350 (Euro 3)
TYPE	Turbo intercooler, diesel
NUMBER OF CYLINDERS	6
TOTAL DISPLACEMENT	8,9 lt
MAXIMUM POWER	350 PS (258 kW) @ 2100 rpm
MAXIMUM TORQUE	1550 Nm @ 1400 rpm
FUEL INJECTION	
MAKE/MODEL	Cummins CCR (Common Rail)
FUEL TANK CAPACITY	230 / 300 lt
CLUTCH	
TYPE	Multi dry disc, air assisted hydraulic
DRIVEN PLATE DIAMETER	430 mm (17")
GEAR BOX	
MAKE/MODEL	ZF 16 S 1820 TO NMV221
NUMBER OF GEARS	16 forward synchromesh, 2 reverse
FRONT AXLE	
TYPE, CAPACITY	"I" section forged steel, 8000 kg
REAR AXLE	
MAKE / TYPE	BMC 300T / 300TC
NUMBER OF SPEEDS	Single speed, hub reduction
AXLE RATIO	6.03:1
CAPACITY	26000 kg
STEERING SYSTEM	
STEERING BOX MAKE/MODEL	HEMA (ZF) 8098 Servocom
TYPE	Integral type, hydraulic
BRAKE SYSTEM	
	Full air service brake, air actuated spring parking brake, ABS/ASR, Jacobs brake
SUSPENSION	
FRONT AXLE	Semi elliptic leaf spring + shock absorbers
REAR AXLE	Tandem leaf spring + shock absorbers
ANTI-ROLL BAR	Front
CHASSIS	
PROFILE TYPE	"C" section steel profile
REINFORCEMENT TYPE	"C" section, inner flitch
TYRES	315 / 80 R 22.5, 10+1 tubeless
RIMS	9.00 x 22.5, 10 wheel nuts
ELECTRICAL SYSTEM	
VOLTAGE	24 V, negative (-) ground
BATTERIES	2 x 12 V, 150 Ah
ALTERNATOR	70 A
STARTER MOTOR	24 V, 7.8 kW

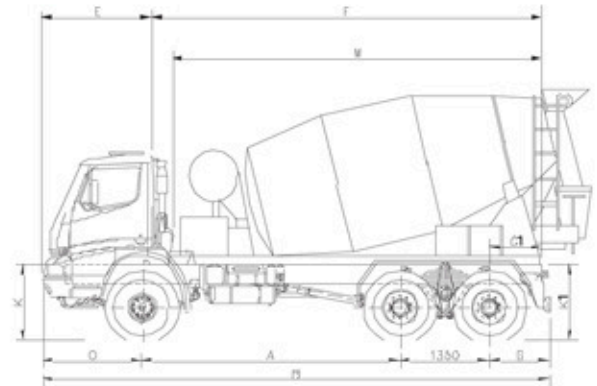

DIMENSIONS (mm)

A: Wheelbase	3900
B: Overall length	8385
C: Overall width	2500
D: Overall height	2870
E: Bumper to back of cab	1696
F: Back of cab to end of frame	6559
G: Rear overhang	1630
G1: Chassis rear overhang	1500
H: Front track	2070
J: Rear track	1838
K: Frame height on front axle	1110
K1: Frame height on rear axle	1130
M: Useful chassis length	6364
N: Frame width-front	975
N1: Frame width-rear	800
O: Front overhang	1505

WEIGHTS (kg)

Kerb weight	9400
Kerb weight, front axle	4220
Kerb weight, rear axle	5180
Payload (including body)	23600
Max. permissible total weight, front	7000
Max. permissible total weight, rear	26000
Gross vehicle weight	33000

PERFORMANCE

Gradeability (at GVW) (%)	>35
Max. geared speed (km/h)	80

ADDITIONAL INFORMATION

Cruise Control, Cable Shift System