



ALL NEW!

Telescoping Boom • Single Cummins Engine • 4x2 or 4x4 • 24 Volt System



470TM Telescoping Boom Excavator

**Highway speed excavator with the latest in technology —
Drive and dig from the upper cab**

Model 470TM

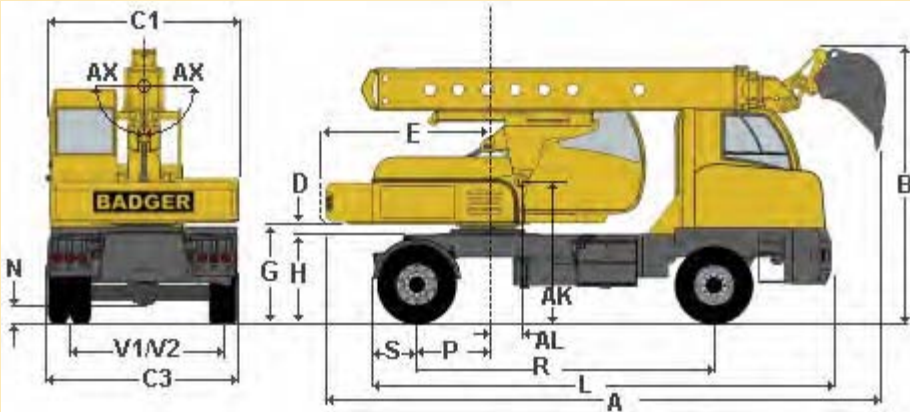

Travel Position Without Bucket

4 x 4

Length: 23'0" (7.02m)
 Height: 11'3" (3.42m)
 Weight: 37,500 lbs. (17,010 kg)
 Front Axle Weight: 17,308 lbs. (7,851 kg)

4 x 2

Length: 23'0" (7.02m)
 Height: 11'3" (3.42m)
 Weight: 37,000 lbs. (16,783 kg)
 Front Axle Weight: 16,808 lbs. (7,624 kg)

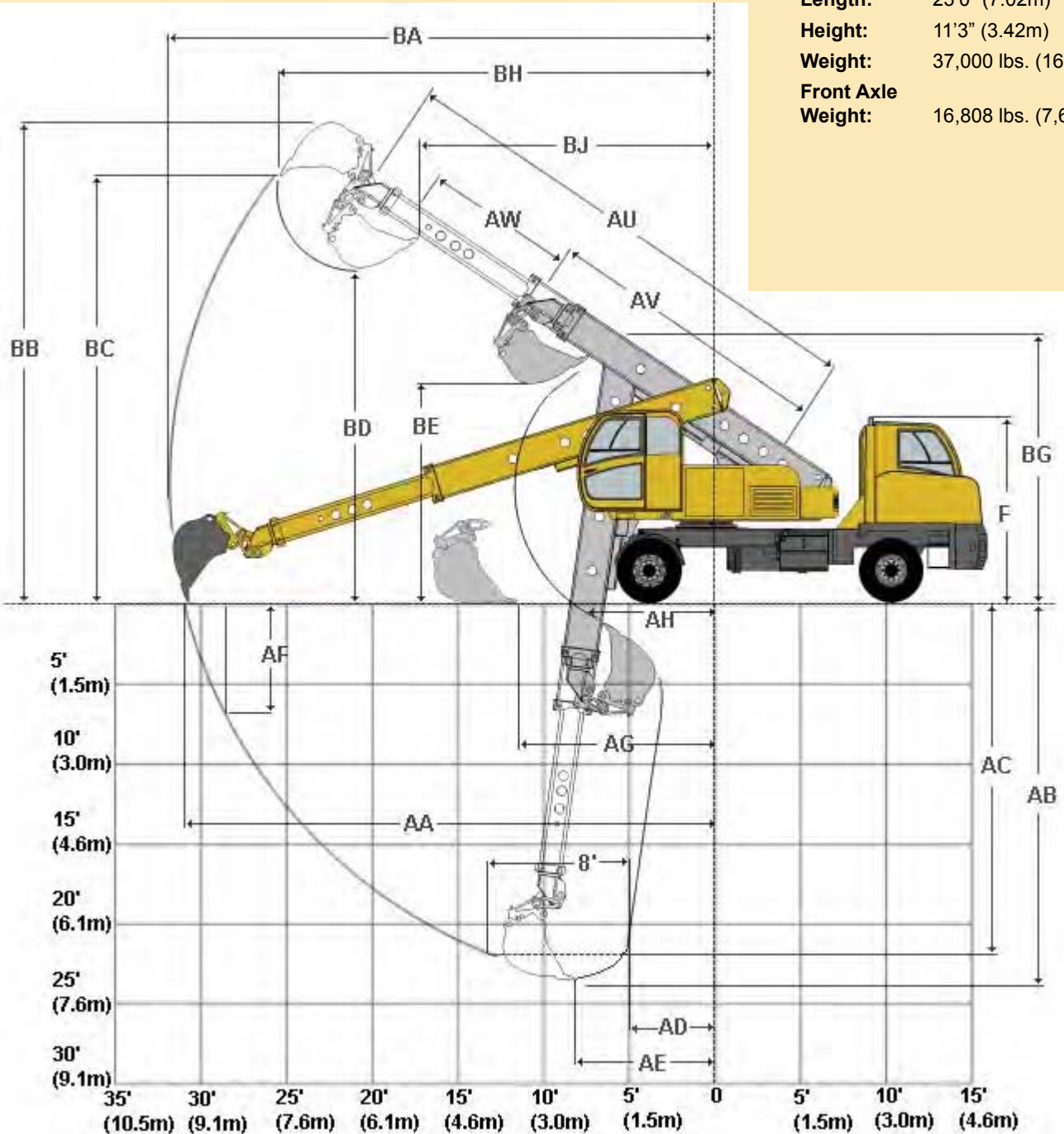

Specifications

Transport Dimensions - U.S. (Metric)

Adjust-A-Boom:		Retracted	Extended	Adjust-A-Boom:		Retracted	Extended
A	Overall length, transport position	25'7" (7.80m)	28'7" (8.71m)	H	Top of fender to groundline	4'4" (1.32m)	4'4" (1.32m)
B	Overall height	12'6" (3.80m)	12'6" (3.80m)	L	Length of Undercarriage	21'7" (6.57m)	21'7" (6.57m)
C1	Width of Upperstructure	8'6" (2.44m)	8'6" (2.44m)	N	Ground Clearance (SAE J1234)	0'10" (0.25m)	0'10" (0.25m)
C2	Width of Carrier	8'7" (2.46m)	8'7" (2.46m)	P	Rear axle to axis of rotation	3'4" (1.02m)	3'4" (1.02m)
D	Upper-Carrier Min. Clearance	0'3" (0.04m)	0'3" (0.04m)	R	Wheelbase	160" (4.06m)	160" (4.06m)
E	Swing clearance	7'6" (2.29m)	7'6" (2.29m)	S	Rear axle to rear of fender	2'10" (0.87m)	2'10" (0.87m)
F	Top of exhaust to groundline	10'1" (3.08m)	10'1" (3.08m)	V1	Tread, rear axle	7'1" (2.00m)	7'1" (2.00m)
G	Clearance, upper to groundline	4'8" (1.37m)	4'8" (1.37m)	V2	Tread, front axle	7'0" (1.98m)	7'0" (1.98m)

Travel Speeds - mph

4x2 and 4x4	Lo-Lo	Low	1st	2nd	3rd	4th	5th	6th	7th	8th	Hi-R	Low-R	LL-R
Manual (Low Range)	1.5	2.4	3.6	4.8	6.5	8.8	12.1	16.3	22.2	30.0	7.7	2.2	1.5
(Eaton Fuller) (Hi Range)	3.4	5.3	7.9	10.7	14.6	19.6	27.1	36.4	49.6	59.0	17.1	5.0	3.3
(RTO-11908LL)													
Auto (Low Range)	NA	3.6	6.6	9.4	13.9	21.6	29.1	35.0	NA	NA	4.2	NA	NA
(Allison RDS 3500) (Hi Range)	NA	8.1	14.7	20.9	31.0	48.1	53.0	59.0	NA	NA	9.3	NA	NA

Working Range - U.S. (Metric)

Adjust-A-Boom:		Retracted	Extended
AA	Maximum radius at groundline (165° pivot)	28'5" (8.67m)	31'6" (9.60m)
AB	Maximum digging depth (165° pivot)	20'6" (6.25m)	23'6" (7.15m)
AC	Maximum depth for 8' (2.50m) level cut	18'11" (5.77m)	22'0" (6.70m)
AD	Minimum radius of 8' (2.50m) level cut at depth "AC"	4'7" (1.39m)	5'1" (1.54m)
AE	Radius of maximum digging depth	7'11" (2.42m)	8'4" (2.55m)
AF	Maximum depth of vertical wall which can be excavated (165° pivot)	4'6" (1.36m)	5'11" (1.80m)
AG	Minimum level cut radius with bucket on groundline	11'1" (3.38m)	14'1" (4.28m)
AH	Minimum radius at groundline	6'4" (1.94m)	10'5" (3.17m)
AK	Boom pivot to groundline	6'5" (1.96m)	6'5" (1.96m)
AL	Boom pivot to axis of rotation	1'6" (0.46m)	1'6" (0.46m)
AP	Bucket tooth radius (standard bucket)	4'9" (1.45m)	4'9" (1.45m)
AP	Bucket tooth radius (reversed bucket)	6'0" (1.82m)	6'0" (1.82m)
AQ	Boom pivot angle (32.50° above) (82° below)	114.50°	114.50°
AS	Bucket pivot angle	165°, 148°	165°, 148°
AU	Maximum telescoping boom length (boom pivot to bucket pivot)	22'10" (6.97m)	25'10" (7.88m)
AV	Minimum telescoping boom length (boom pivot to bucket pivot)	12'4" (3.77m)	15'4" (4.68m)
AW	Telescoping travel	10'6" (3.20m)	10'6" (3.20m)
AX	Bucket tilt angle (both sides of center)	90°	90°
BA	Maximum radius of working equipment (165° pivot)	29'2" (8.90m)	32'2" (9.81m)
BB	Maximum height of working equipment (165° pivot)	25'2" (7.68m)	26'10" (8.17m)
BC	Maximum bucket tooth height	23'6" (7.15m)	25'1" (7.64m)
BD	Minimum clearance of bucket teeth, with bucket pivot at max height	16'10" (5.14m)	18'6" (5.63m)
BE	Minimum clearance of fully curled bucket at max boom height	12'5" (3.78m)	14'0" (4.28m)
BF	Minimum clearance of bucket teeth, at max boom height	11'3" (3.42m)	12'10" (3.91m)
BG	Maximum height of working equipment with bucket below groundline	14'2" (4.33m)	11'3" (3.42m)
BH	Radius of bucket teeth at maximum height	23'4" (7.11m)	25'10" (7.89m)
BJ	Minimum radius of bucket teeth at maximum bucket pivot height	15'5" (4.69m)	17'11" (5.46m)

DIMENSIONS ARE FOR A BUCKET MOUNTED IN THE 148° BUCKET PIVOT ANGLE POSITION, EXCEPT AS NOTED.

Model 470TM Specifications

Engine

Cummins:

- QSB 6.7 Tier 3, 215hp @ 2500 rpm, 655 ft-lb @ 1500 rpm

Optional:

- QSB 6.7 Tier 4i, 225hp @ 2500 rpm, 655 ft-lb @ 1500 rpm

- ISB 6.7 On Highway, 220hp @ 2300 rpm, 520 ft-lb @ 1600 rpm

Electrical System:

- 24 Volt, 70 amp alternator

Fuel System:

- Diesel 100 gallon capacity

Transmission

Manual (Standard):

- Eaton Fuller RTO-11908LL

- 10 speed forward, 3 speed reverse

Automatic (Optional):

- Allison RDS 3500

- 6 speed forward, 1 speed reverse

Transfer Case:

- Fabco TC-270, front axle disconnect and remote propel disconnect

Axles

4x2 Front:

- Eaton - I-220W - 22,000lb (9979kg) rated capacity

4x4 Front:

- Fabco - SDA21000 - 21,000lb (9525kg) rated capacity

Rear:

- Dana - S23-170DW - 23,000lb (10,433kg) rated capacity

Gross axle weight rating:

- 4x2: 41,000lb (18,597kg)

- 4x4: 44,000lb (19,958kg)

Steering

TRW:

- Integral hydraulic power steering gear

Suspension

Front:

- 13 leaf spring with auto-lockout cylinders

Rear:

- Rigid mounted

Brakes

Front:

- 16.5 x 7 Drum Bendix S CAM w/ ABS Sensors

Rear:

- 16.5 x 7 Drum Bendix S CAM w/ ABS Sensors

Wheels

- Hub Piloted 10 stud, 11.25 BC

Tires

Front:

- Single 385/65R22.5 (4x4 and 4x2)

Rear:

- Dual 11R22.5H (4x4 and 4x2)

Frame

- 42" wide reinforced formed plate, trapezoidal section box frame

Cab

- All weather steel cab, isolation mounted, acoustically lined, cloth covered adjustable seat, seat belt, pressurized fresh air heater and defroster, tinted safety glass windows, 2-speed electric windshield wiper-washer, extinguisher, dome light. Full automotive gauge display.

Upperstructure Cab

- All weather steel cab, isolation mounted, acoustically lined, cloth covered adjustable seat with mechanical suspension, tinted safety glass windows with tilt-slide up front window, electronic joystick mounted in each armrest (2).

Standard Equipment

- Sealed halogen high/low beam headlights with high beam indicator LED. Directional, clearance, tail, backup, stop and 4-way hazard lights. West-Coast style and convex mirrors. Dual electric horns. Electric travel alarm.

Optional Equipment

- Air Conditioning

- Strobe Lights

- Emergency pump system

- Manual or Automatic transmission

- Tier 3, Tier 4i or On Highway Cummins engine

- Auxiliary hydraulic boom circuits

- Work lights:

- 2 LED boom mounted lights

- 2 LED cab mounted lights

- 6 LED perimeter lights

- ABS

- High-rail system

- Ditching and excavating buckets are available

-- *Please consult dealer regarding any custom options --*

Hydraulic System

Pumps:

- Main Pump: Variable displacement piston pump

- Flow and pressure compensating

- 0-66 GPM @ 2500 rpm engine speed

- Travel Pump: Variable displacement piston pump

- Hydrostatic

- 0-30 GPM @ 2500 rpm engine speed

- Steering/Carrier Pump: Gear power pump

- 12 GPM

Oil Cooler: Heavy Duty Fin/Tube type, continuously circulating

Filtration System:

- 10 Micron absolute, in-tank element

- Relief valves, visual and electronic Filter indicators

- 100 mesh with 5psi bypass suction strainer for each pump

Oil Capacity: 42 gallon sealed and pressurized, visual oil level indicator

Swing

- Planetary transmission with automatic internal swing parking brake, spring set/hydraulic release, priority circuit axial piston motor. Dynamic braking provided by the hydraulic system. Swing speed 0-9 rpm.

Hydraulic Remote Propel

- Carrier powered by a 89hp hydraulic motor through the carrier transfer case. Travel pedal and steering located in upper cab, front axle suspension and digging brakes engage automatically.

Cylinders

- Hoist: 5.00" ID x 2.50" rod x 44.57" stroke w/ integral load holding valves

- Tool: 4.00" ID x 2.25" rod x 21.59" stroke

- Telescope: 3.00" ID x 2.00" rod x 126" stroke w/ integral load holding valves

- Front axle lockout: 3.0" ID x 1.25" rod x 5.0" stroke, integ. load holding valves

- Cylinder Type Rotary Actuator: 6.0" OD x 180° attachment rotation

with holding valves and cross port relief valves.

- Adjust-A-Boom: 3.5" ID x 2.5" rod x 36.0" stroke w/ holding valves and

cross port relief valves.

Boom

- Fixed, two-section telescoping. Adjustable boom support rollers.

- Option: Adjust-A-Boom, extends boom hydraulically up to 3'

Upperstructure Controls

- Two electronic joystick controls mounted in armrests, one for tool-hoist, one for swing-telescope. Foot pedals for remote travel. Joystick buttons for tool rotation, horn, remote steering. All controls are self-centering, when controls are released movement stops, swing and travel brakes set automatically.



217 Patneau Drive

Winona, Minnesota 55987

Phone: (507) 454-1563

TF: 800-533-8013

Fax: (507) 453-6441

www.badgerequipment.com



A Manitex International Company

Due to continued improvements, all specifications are subject to change without notice.

**New
Dealers &
Distributor
Inquiries
Welcomed**

4x2 Lift Capacities

4x2 and 4x4 Lift Capacities

- All ratings conform to SAE Standard J-1097, and do not exceed 87% of hydraulic capacity or 75% of tipping capacity.
- Lifting over the side is relative to sitting in the carrier cab. Therefore, "left" side is over the carrier cab side.
- Loads with an asterisks (*) indicate loads that are limited by tipping conditions. All other loads are limited by hydraulic capacity. Stability limitations are based on front axle suspension being "locked out".
- The rated lift capacities pertain to the machine as originally manufactured and equipped with 6500lb (2948kg) counterweight. Bucket weight not included.
- The load point is located on the bucket pivot point.
- Do not attempt to gain additional radius by wrapping the load line around the back of the bucket.
- The bucket shall be fully curled under the boom.
- The weights of slings and any auxiliary lifting devices must be deducted from the rated loads to determine the net load that may be lifted.
- **CAUTION:** All rated loads are based on the machine being on a level, uniform supporting surface. User is expected to make due allowances for particular job conditions, such as soft or uneven ground, ground out of level, side loads, jerking, hazardous conditions, experience or personnel, etc. Operator and other personnel should fully acquaint themselves with the Operator's Manual furnished by the manufacturer before operating machine, and should adhere at all times to the rules for safe operation of equipment. Operators and supervisors should also acquaint themselves with the latest PCSA Standards for mobile hydraulic excavators.
- **DO NOT** attempt to pick and carry a load without having the front axle lock-out system in the "pick and carry" mode.

4x2 - LIFT HEIGHT - LOAD RADIUS: ADJUST-A-BOOM RETRACTED - lbs (kg)

Lift Height	Over Rear	Over L. Side	Over R. Side	Over Rear	Over L. Side	Over R. Side	Over Rear	Over L. Side	Over R. Side	Over Rear	Over L. Side	Over R. Side	Over Rear	Over L. Side	Over R. Side	Radius @
	10' (3.05m)			13.9' (4.2m)			15' (4.57m)			20' (6.10m)			Max. Radius			
+20' (6.10m)													2730 (1238)	2730 (1238)	2730 (1238)	20.3' (6.19m)
+15' (4.57m)							5940 (2694)	5940 (2694)	5940 (2694)	4040 (1832)	4040 (1832)	4040 (1832)	3220 (1460)	3220 (1460)	3220 (1460)	23.0' (7.10m)
+10' (3.05m)				8520 (3863)	7780* (3437)	8440* (3736)	7600 (3447)	6900* (3038)	7470* (3297)	4830 (2190)	4400* (1905)	4740* (2059)	3400 (1542)	3170* (1347)	2390* (1447)	24.4' (7.44m)
+5' (1.52m)							7630 (3460)	6520* (2866)	7060* (3111)	4960 (2249)	3590* (1818)	4530* (1964)	3470 (1574)	3010* (1274)	3210* (1365)	24.6' (7.5m)
Ground Level							6590 (2988)	6120* (2685)	6620* (2911)	4570 (2072)	4000* (1723)	4300* (1859)	3510 (1592)	3060* (1297)	3270* (1392)	23.7' (7.22m)
-5' (1.52m)	7330 (3324)	7330 (3324)	7330 (3324)				5430 (2462)	5430 (2462)	5430 (2462)	3980 (1805)	3820* (1642)	4100* (1769)	3590 (1628)	3400* (1451)	3640* (1560)	21.6" (6.59m)
-10' (3.05m)	6140 (2784)	6140 (2784)	6140 (2784)				4520 (2050)	4520 (2050)	4520 (2050)				3860 (1750)	3860 (1750)	4060* (1750)	17.7' (5.40m)
-15' (4.57m)	5410 (2453)	5410 (2453)	5410 (2453)													

4x2 - LIFT HEIGHT - LOAD RADIUS: ADJUST-A-BOOM EXTENDED - lbs (kg)

Lift Height	Over Rear	Over L. Side	Over R. Side	Over Rear	Over L. Side	Over R. Side	Over Rear	Over L. Side	Over R. Side	Over Rear	Over L. Side	Over R. Side	Over Rear	Over L. Side	Over R. Side	Radius @
	10' (3.05m)			15' (4.57m)			20' (6.10m)			25' (7.62m)			Max. Radius			
+20' (6.10m)													1940 (880)	1940 (880)	1940 (880)	23.9' (7.29m)
+15' (4.57m)				5460 (2476)	5460 (2476)	5460 (2476)	3680 (1669)	3680 (1669)	3680 (1669)	2510 (1138)	2510 (1138)	2510 (1138)	2280 (1034)	2280 (1034)	2280 (1034)	26.2' (7.99m)
+10' (3.05m)							4470 (2027)	4110* (1773)	4540* (1968)	2950* (1338)	2820* (1188)	3070* (1301)	2440 (1106)	2380* (988)	2580* (1079)	27.4' (8.35m)
+5' (1.52m)							4610 (2091)	3920* (1687)	4320* (1868)	3080* (1397)	2710* (1138)	3150* (1247)	2520 (1143)	2270* (939)	2450* (1020)	27.6' (8.41m)
Ground Level							4250 (1927)	3750* (1610)	4120* (1778)	2940* (1333)	2590* (1084)	3020* (1188)	2570 (1165)	2290* (948)	2480* (1034)	26.8' (8.17m)
-5' (1.52m)				5120 (2322)	5120 (2322)	5120 (2322)	3700 (1678)	3600* (1542)	3700 (1678)	2660* (1206)	2500* (1043)	2920* (1143)				
-10' (3.05m)	5910 (2680)	5910 (2680)	5910 (2680)	4270 (1936)	4270 (1936)	4270 (1936)	3150 (1428)	3150 (1428)	3150 (1428)				2830 (1283)	2830 (1283)	2830 (1283)	21.8' (6.65m)
-15' (4.57m)	5230 (2372)	5230 (2372)	5230 (2372)	3650 (1655)	3650 (1655)	3650 (1655)							3360 (1524)	3360 (1524)	3360 (1524)	16.3' (4.97m)

4x4 Lift Capacities

4x4 - LIFT HEIGHT - LOAD RADIUS: ADJUST-A-BOOM RETRACTED - lbs (kg)

Lift Height	Over Rear	Over L. Side	Over R. Side	Over Rear	Over L. Side	Over R. Side	Over Rear	Over L. Side	Over R. Side	Over Rear	Over L. Side	Over R. Side	Over Rear	Over L. Side	Over R. Side	Radius @
	10' (3.05m)			13.9' (4.2m)			15' (4.57m)			20' (6.10m)			Max. Radius			
+20' (6.10m)													2730 (1238)	2730 (1238)	2730 (1238)	20.3' (6.19m)
+15' (4.57m)							5940 (2694)	5940 (2694)	5940 (2694)	4040 (1832)	4040 (1832)	4040 (1832)	3220 (1460)	3220 (1460)	3220 (1460)	23.0' (7.10m)
+10' (3.05m)				8520 (3863)	7970* (3524)	8620* (3818)	7600 (3447)	7070* (3115)	7640* (3374)	4830 (2190)	4520* (1959)	4860* (2113)	3400 (1542)	3260* (1388)	3490* (1492)	24.4' (7.44m)
+5' (1.52m)							7630 (3460)	6680* (2939)	7400* (3183)	4960 (2249)	4330* (1873)	4650* (2018)	3470 (1574)	3100* (1315)	3310* (1410)	24.6' (7.5m)
Ground Level							6590 (2988)	6280* (2757)	6780* (2984)	4570 (2072)	4110* (1773)	4420* (1914)	3510 (1592)	3150* (1338)	3270* (1392)	23.7' (7.22m)
-5' (1.52m)	7330 (3324)	7330 (3324)	7330 (3324)				5430 (2462)	5430 (2462)	5430 (2462)	3980 (1805)	3930* (1691)	4180* (1805)	3590 (1628)	3490* (1492)	3740* (1605)	21.6" (6.59m)
-10' (3.05m)	6140 (2784)	6140 (2784)	6140 (2784)				4520 (2050)	4520 (2050)	4520 (2050)				3860 (1750)	3860 (1750)	3860 (1750)	17.7' (5.40m)
-15' (4.57m)	5410 (2453)	5410 (2453)	5410 (2453)													

4x4 - LIFT HEIGHT - LOAD RADIUS: ADJUST-A-BOOM EXTENDED - lbs (kg)

Lift Height	Over Rear	Over L. Side	Over R. Side	Over Rear	Over L. Side	Over R. Side	Over Rear	Over L. Side	Over R. Side	Over Rear	Over L. Side	Over R. Side	Over Rear	Over L. Side	Over R. Side	Radius @
	10' (3.05m)			15' (4.57m)			20' (6.10m)			25' (7.62m)			Max. Radius			
+20' (6.10m)													1940 (880)	1940 (880)	1940 (880)	23.9' (7.29m)
+15' (4.57m)				5460 (2476)	5460 (2476)	5460 (2476)	3680 (1669)	3680 (1669)	3680 (1669)	2510 (1138)	2510 (1138)	2510 (1138)	2280 (1034)	2280 (1034)	2280 (1034)	26.2' (7.99m)
+10' (3.05m)							4470 (2027)	4230* (1827)	4640* (2013)	2950 (1338)	2710 (1230)	2950 (1338)	2440 (1106)	2270* (1029)	2440 (1106)	27.4' (8.35m)
+5' (1.52m)							4610 (2091)	4050* (1746)	4440* (1929)	3080 (1397)	2800* (1179)	3040* (1285)	2520 (1143)	2350* (975)	2530* (1057)	27.6' (8.41m)
Ground Level							4250 (1927)	3870* (1664)	4240* (1832)	2940 (1333)	2680* (1125)	2910* (1229)	2570 (1165)	2380* (988)	2560* (1070)	26.8' (8.17m)
-5' (1.52m)				5120 (2322)	5120 (2322)	5120 (2322)	3700 (1678)	3720* (1596)	3900* (1678)	2660 (1206)	2590* (1084)	2810* (1183)				
-10' (3.05m)	5910 (2680)	5910 (2680)	5910 (2680)	4270 (1936)	4270 (1936)	4270 (1936)	3150 (1428)	3150 (1428)	3150 (1428)				2830 (1283)	2830 (1283)	2830 (1283)	21.8' (6.65m)
-15' (4.57m)	5230 (2372)	5230 (2372)	5230 (2372)	3650 (1655)	3650 (1655)	3650 (1655)							3360 (1524)	3360 (1524)	3360 (1524)	16.3' (4.97m)

Due to continued improvements, all specifications are subject to change without notice.

For a complete list of optional equipment or to schedule a demo please see your Authorized Badger Dealer or visit

www.badgerequipment.com



217 Patneaude Drive
Winona, Minnesota 55987
Phone: (507) 454-1563
TF: 800- 533-8013
Fax: (507) 453-6441
www.badgerequipment.com



A Manitex International Company