

*For a  
fast trip  
cycle*

# THE AUTOCAR DC 103 D-0H

**PLANETARY PACKAGED**

Off-highway rear dump truck  
with planetary-gear rear axle



A new, tough vehicle to speed all kinds of off-highway work, especially road construction. Delivers excellent low gear performance and a loaded top speed of 39 mph.

**AUTOLIT**



Automobile - Truck - Motorcycle 1900 to Present  
ORIGINAL Sales Brochures, Manuals, Books, Posters,  
Catalogs, and MUCH More. World's largest selection!



*A fast trip cycle with  
outstanding economy  
and reliability*

The Autocar DC 103 D-OH Planetary Packaged is designed to bring new standards of speed, performance and durability to construction, quarry and mining operators who want to move a lot of material in a hurry. With speeds as high as 39 mph, this giant truck greatly reduces round-trip time. Whether you rate it by tonnage or yardage hauled, or by operating cost, or by the thousands of hours of heavy-duty work built into it, you'll agree that the DC 103 D-OH Planetary Packaged is a truck which helps you wind up every contract on schedule.



THE HEART OF IT is the planetary-gear rear axle. A "sun" gear at the end of the rear axle shaft meshes with three pinion or "planet" gears which in turn drive each rear wheel. Owing to multiple gear-tooth contacts, it provides high torque capacity.



**AUTOCAR DRIVER CAB.** Designed and built to provide maximum strength and durability, the Autocar Driver Cab permits the operator to put in a full day without fatigue. Full hydraulic power steering makes this mighty truck as easy to handle as a passenger car. The famous "Full-Adjust" Driver's Seat allows the driver to find his own most comfortable position.

**AUTOLIT**



Automobile - Truck - Motorcycle 1900 to Present  
ORIGINAL Sales Brochures, Manuals, Books, Posters,  
Catalogs, and MUCH More. World's largest selection!





**THE PLANETARY GEAR REAR AXLE** places the highest numerical gear reduction right in the wheels. This means that axle shafts and hypoid gears carry only nominal torsional loads and give long trouble-free service. Extra long life, extra dependability, extra economy.



**GOOD GROUND CLEARANCE, TOO.** Because the axle ratio is divided between the gear carrier mounted at the center of the rear axle and the planetary reductions at the outer ends, the main drive gears are reduced in diameter. Thus the housing that covers them is substantially smaller and offers greater clearance—an important feature when operating over rough terrain.



**GREAT FLEXIBILITY.** Fast axle ratios plus 10-speed transmission permit the DC 103 D-OH Planetary Packaged to operate at higher speeds on up-grades as well as level.



**70° DUMPING ANGLE** provided by double-acting hydraulic hoist.

#### BUILT TO LAST

- Bolted construction throughout to hold components firmly. Yet any part can be quickly replaced when necessary.
- Replaceable bushings at more than 100 key points save wear on more expensive major parts.
- Reinforced, heat-treated alloy steel frame for maximum strength.

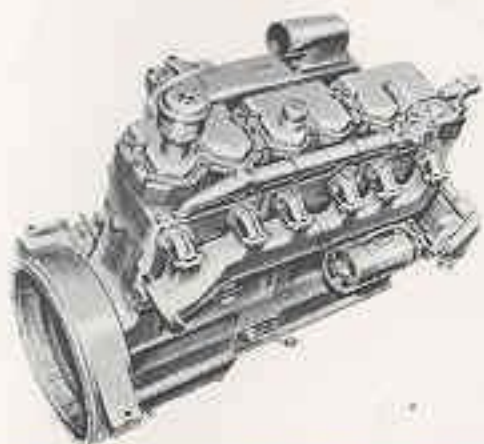

**AUTOCAR-CUMMINS DIESEL ENGINES.** Engines for the DC 103 D-OH Planetary Packaged are the Cummins 8-cylinder, valve-in-head diesel known by engineers the world over for quality, ruggedness and long operating life. Operators are offered as standard the NH engine delivering 220 hp at 2100 rpm. Optional equipment is the NT with 250 hp or the NTO with 262 hp.

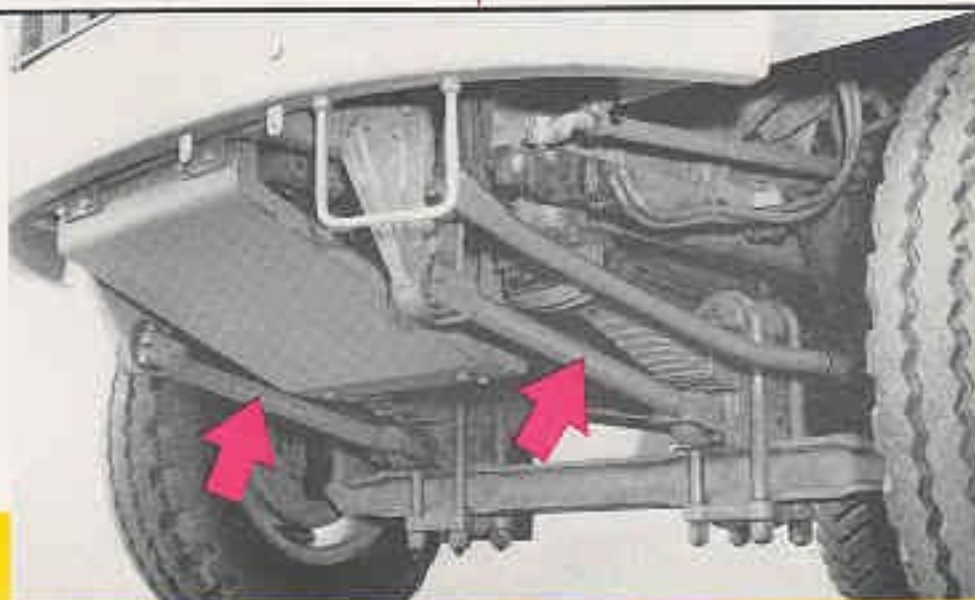

**HEAVY-DUTY RADIUS RODS,** front and rear, hold axles in alignment with frame, provide the rigid construction that reduces stresses.

**AUTOLIT**



Automobile - Truck - Motorcycle 1900 to Present  
ORIGINAL Sales Brochures, Manuals, Books, Posters,  
Catalogs, and MUCH More. World's largest selection!



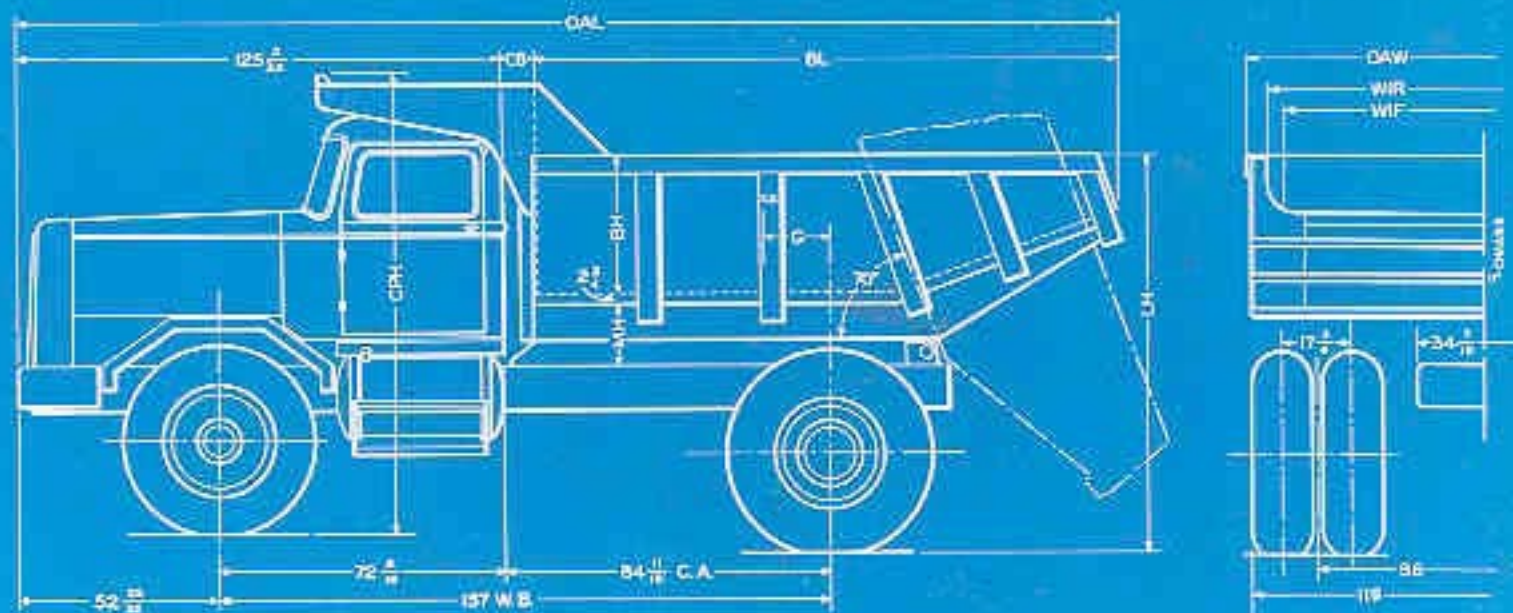

## AUTOCAR MODEL DC 103 D-OH Planetary Packaged

### DIMENSIONS, WEIGHTS AND CONDENSED SPECIFICATIONS

#### WEIGHT DISTRIBUTION DATA

	Front	Rear	Total
Chassis	10,400	9,400	19,800
Body and Hoist	1,400	11,800	13,200
Tare Weight	11,800	21,200	33,000
Payload	3,200	26,800	30,000
Gross Weight	15,000	48,000	63,000

**NOTE:** Chassis weight includes cab, fuel, oil, water, standard nuts, and 12.00/24 front, 14.00/24 dual rear tires.

#### CONDENSED SPECIFICATIONS

**PAYLOAD RATING:** 15 tons

**CAPACITY (STRUCK):** 10 cu. yd.

**ENGINE:** Cummins diesel; 220 to 262 hp available

**TRANSMISSION:** 10-speed mechanical with 14' 2-plate clutch

**FRONT AXLE:** Wide track, heavy-duty type

**REAR AXLE:** Autocar PR-100 planetary

**SPRINGS:** Free-floating type

**RADIUS RODS:** Front and rear, heavy-duty

**FRAME:** Heat-treated alloy steel with bolted construction

**BRAKES:** 4 wheel air; front: 17 1/4" x 4", lining area per axle, 250 sq. in.; rear: 20 1/2" x 7", lining area per axle, 656 sq. in.

**STEERING:** Hydraulic power assist

**TIRES:** 12.00/24 16-ply rating (front); 14.00/24 20-ply rating (dual rear)

**CAB:** Autocar Driver Cab with "Full Adjust" Seat

**BODY:** Heavy rock-type body with scoop end; full cab protector, 10 cu. yd. capacity

**HOIST:** Twin-cylinder double acting hydraulic; full 70° dumping angle



**AUTOCAR DIVISION**  
The White Motor Company • Exton, Pa.

