

# Minetruck MT6020

## Technical specification

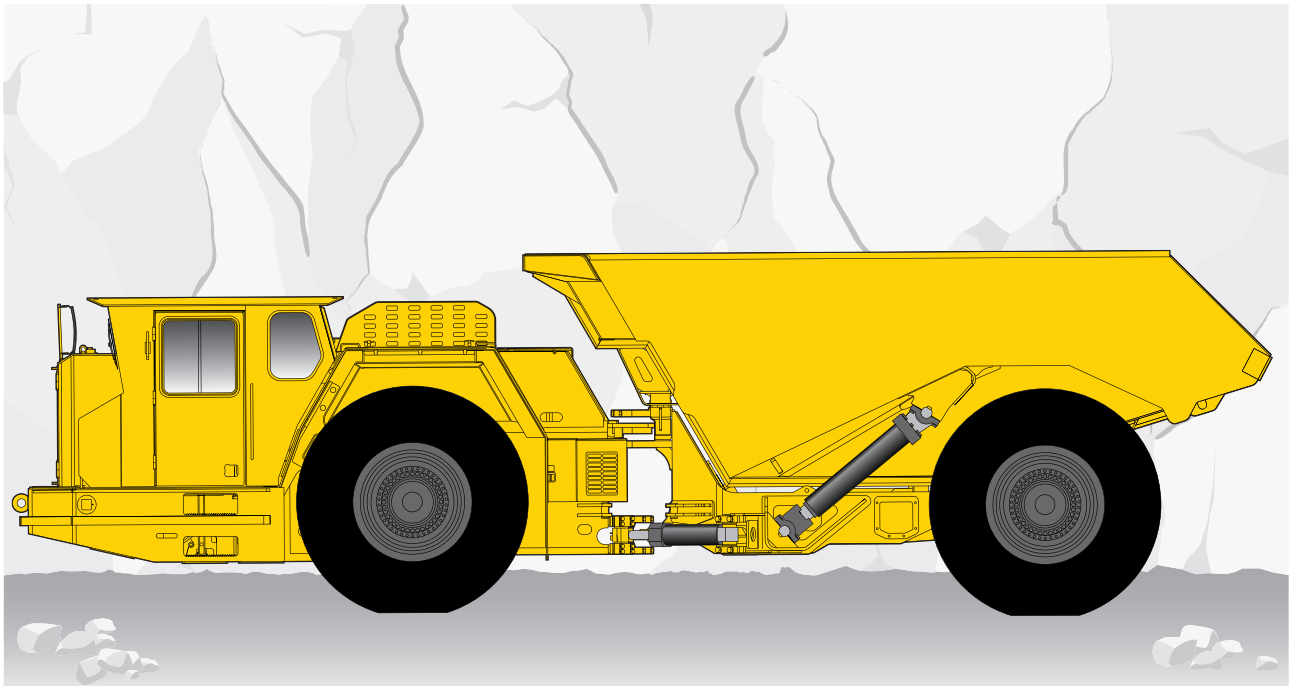

The Minetruck MT6020 is a fast 60 metric tonne capacity articulated underground truck, with an ergonomically designed operator's compartment for unparalleled productivity in demanding mines.

### Features

#### Dump box

- Optimum box profile for clean and fast dumping
- Box support and lock for safe work under box

#### Operator's compartment

- Ergonomically and spacious designed compartment for maximum safety and minimal operator fatigue with:
  - Forward seating enclosed cabin
  - ISO ROPS/FOPS certified for maximum safety
  - Air conditioning for comfortable working conditions
  - Tilt-telescopic steering wheel
  - Trainer seat
  - Compliant with sound regulations to minimize operator's fatigue; reduced noise level to 83 dB(A) inside the cab
  - Wide windows for safety and enhanced operator's visibility
  - 3 point mounting points for entry and exit from operator's compartment
  - Back up camera and monitor for operator assistance

#### Power frame

- Front axle suspension, a gas-hydraulic system for improved operator comfort and vehicle handling
- Atlas Copco unique powertrain includes an upbox, a drop box and a combined transmission and converter which improves visibility and accessibility to components
- Electronic transmission and engine control system for smooth and precise shifting
- A high power-to-weight ratio
- High horsepower per tonne loaded

#### General

- Great serviceability with centralized service points
- Long-life roller bearing centre hinge
- Anti skid material at service access points
- Central manual lubrication
- Hydraulic hoses, electric cables and hot surfaces are well routed and protected

# Specifications

## Capacities

### SAE

Tramming capacity	60 000 kg
-------------------	-----------

## Motion times

### Dump box

Dumping	15 seconds
---------	------------

## Engine

- Cummins..... QSK19-C760, EPA Tier 1/EU Stage I A
- Power rating at 2 100 rpm ..... 567 kW/760 hp
- Maximum torque at 1 300 rpm ..... 3 084 Nm
- Catalytic exhaust purifier and silencer
- Dry type air cleaner
- Exhaust heat protection
- Engine oil drain

## Transmission and converter

- Planetary, automatic 6 speeds forward/2 speeds reverse with integral single stage converter with automatic lock up
- Allison.....M6610AR
- Up box: Power transmitted through a 1:1 gear ratio box
- Drop box: Power transmitted through a 1:1 gear ratio box

## Axles

- Kessler ..... 111
- Conventional front and rear differential
- Front-axle oscillating suspension "A" frame with hydraulic suspension cylinders and accumulator cushioning
- All wheel drive

## Brakes

Fully enclosed, force cooled, multiple wet discs at each wheel end

- Service/parking/emergency brakes ..... SAHR
- Hydraulic retarder

## Tyres

Tubeless, steel radial, lug tread design for underground mine service

- Dimensions ..... 35/65, R33\*

*\* As applications and conditions vary, Atlas Copco recommends that the user consults with tyre suppliers to obtain the optimum tyre selection*

## Operator's compartment

- Forward facing seat
- Cabin; ISO ROPS/FOPS approved
- KAB 555 seat with retractable seat belts
- Air conditioner
- Trainer seat
- Back up video monitor

## Suspension

The suspension is a gas-hydraulic system for improved operator comfort and vehicle handling while minimizing frame stress

- Suspension, max ..... 105 mm
- Individual self leveling suspension

## Hydraulic system

- System pressure ..... 20.7 MPa
- Hydraulic tank capacity ..... 238 litres
- Filtration, return line ..... 4.0 µm
- Heavy duty gear type pumps.
- Cylinders diameter:
  - Steer cylinders (2) ..... 160 mm
  - Dump cylinders (2) ..... 177.8 mm
  - Suspension cylinders (2) ..... 125 mm

## Electrical system

- Voltage, system start & accessories ..... 24 V
- Alternator, high output ..... 100 A
- Hydraulic warning system; temperature, hyd. oil level
- Rock Tough projection lights
- Isolation switch lockout

## Fuel

- Fuel tank capacity ..... 844 litres
- Fuel consumption, full load ..... 67 litres/hour
- Fuel filtration ..... 10 µm
- Anti-siphon fuel supply

## Turning radius

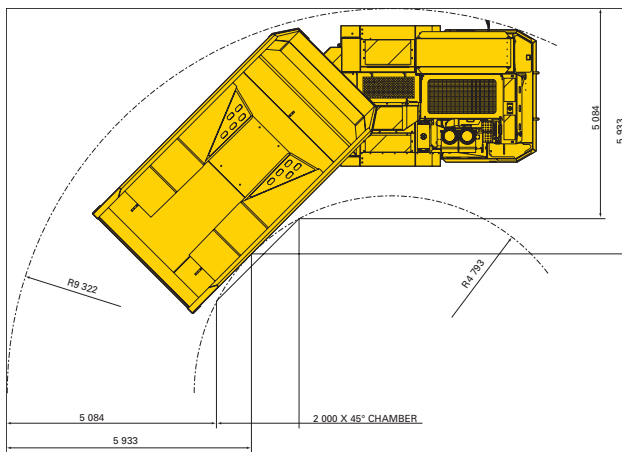

- Turning angle +/-42.5°
- Dimensions shown are based on standard vehicle configuration with 27 mm tyre deflection
- All dimensions are shown in millimetres

## Grade performance

NB. 3% rolling resistance assumed. Actual performance may vary depending on the application

### Standard configuration, box empty

Percent grade	0.0	2.0	4.0	6.0	8.0	10.0	12.0	14.0	16.0	18.0	20.0
Ratio					1:12	1:10	1:8	1:7			1:5
1st gear (km/h)	6.4	6.4	6.3	6.3	6.3	6.3	6.3	6.3	6.3	6.3	6.3
2nd gear (km/h)	9.5	9.5	9.4	9.4	9.4	9.4	9.3	9.3	9.3	9.3	9.2
3rd gear (km/h)	12.6	12.6	12.5	12.5	12.4	12.4	12.4	12.3	12.3	12.2	12.2
4th gear (km/h)	18.3	18.2	18.2	18.1	18.0	17.9	17.8	17.7	17.6	17.5	17.1
5th gear (km/h)	25.2	25.1	24.9	24.7	24.5	24.3	24.2	23.2	21.2		
6th gear (km/h)	37.5	37.1	36.7	36.3	35.6	30.9					

### Standard configuration, box loaded

Percent grade	0.0	2.0	4.0	6.0	8.0	10.0	12.0	14.0	16.0	18.0	20.0
Ratio					1:12	1:10	1:8	1:7			1:5
1st gear (km/h)	6.3	6.3	6.3	6.2	6.2	6.2	6.2	6.1	6.1	6.1	6.0
2nd gear (km/h)	9.4	9.3	9.3	9.2	9.2	9.1	9.0	9.0	8.3	7.3	
3rd gear (km/h)	12.5	12.4	12.3	12.2	12.1	11.9	10.6				
4th gear (km/h)	18.1	17.9	17.6	17.2	13.5						
5th gear (km/h)	24.8	24.3	22.5								
6th gear (km/h)	36.5	31.7									

## Optional equipment

### Main frame

- Wheel chocks and chock brackets

### Ergonomic

- Grammer seat with retractable seatbelts
- Heater

### System

- Ansul dual bottle fire suppression with engine shutdown
- Electric hydraulic tank fill pump

- Diesel fuel filter with heater and water separation (7 micron)

- Lincoln auto lube with timer
- Wiggins fast fuel-, transmission-, hydraulic- oil fill

### Drive train

- Neutral brake apply

### Electrical system

- Amber strobe light - power on
- Load lights
- Side light opposite operator
- Tail and brake lights

- Turn signals, front and rear

- 24/12 V power converter
- Loading camera
- Battery heater, 120 V
- Block heater, 120 V
- Hydraulic oil heater, 120 V
- Engine oil heater, 120 V
- Fire extinguisher (9kg)

### Controls and instruments

- Blockout 5th and/or 6th gears
- Emergency steering- accumulator type
- Extended data gauge package

### Power unit

- Epoxy coated radiator

### Documentation

- LinkOne parts catalogue, CD
- Parts and service manual - plasticized

### Parts kit

- 1 000 hour consumables

### Other

- Tool box

## Dump boxes

Dump box data		STD			
Material density (t/m <sup>3</sup> )	1.8	2.0	2.2	2.4	
Volume, SAE struck (m <sup>3</sup> )	30.4	26.6	24.1	21.7	
Volume, Semi-heaped (m <sup>3</sup> )	33.3	29.7	27.3	25.0	
Volume, SAE heaped (m <sup>3</sup> )	36.3	32.8	33.4	28.2	
Width, dump box (mm)	W	3 440	3440	3440	3440
Dump position: Box height, max (mm)	H1	6909	6842	6750	6689
Tramming position: Dump box height (mm)	H2	3462	3263	3122	2993
Dump position: Clearance (mm)	C	471	471	471	471

## Dimensions and weights\*

Approximate net weight.....	43 900 kg
Axle load, front end.....	29 700 kg
Axle load, back end.....	14 200 kg

\*Standard equipped vehicle with empty box

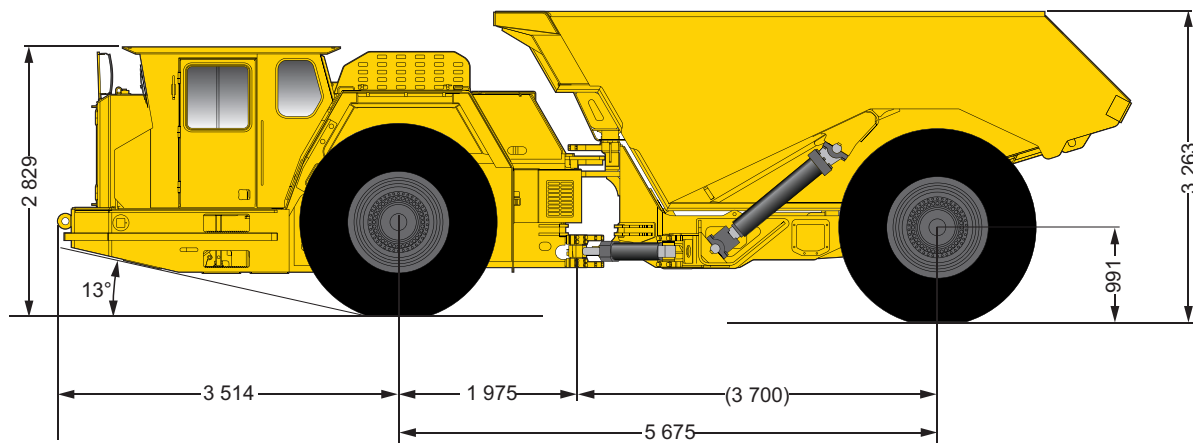

Side view

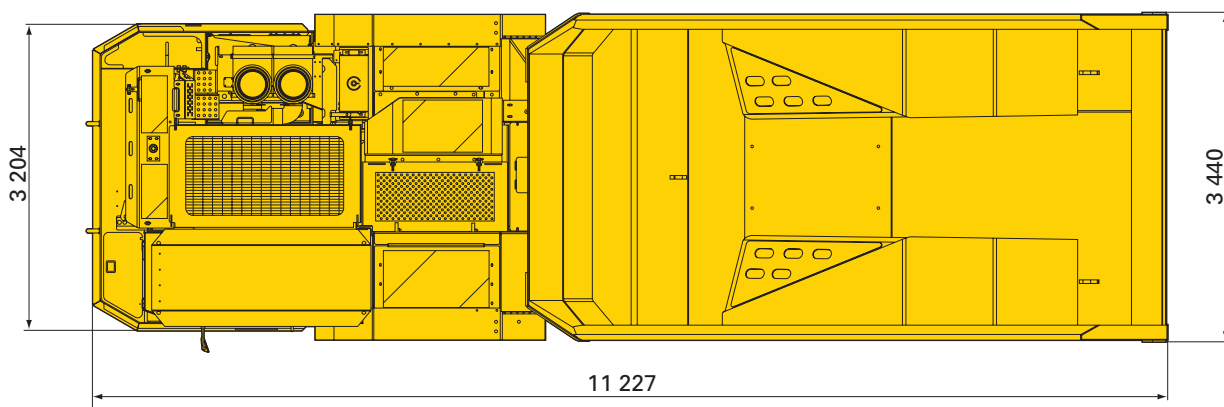

Top view

- Dimensions shown are based on standard vehicle configuration with 27 mm tyre deflection
- All dimensions are shown in millimetres